

CESRTA VACUUM SYSTEM MODIFICATIONS*

Y. Li[#], X. Liu, V. Medjidzade, J. Savino, D. Rice, D. Rubin, M. Palmer
CLASSE, Cornell University, Ithaca, NY 14853

Abstract

In concert with the ILC global design effort, the CESR is being converted into ILC Damping Ring Test Accelerator. The vacuum system is undergoing staged reconfigurations to support both the CEsrTA physics goals and the CHESX X-ray sources. Six superconducting wigglers were moved to a sector with zero-dispersion. This sector is densely populated with beam instrumentation and diagnostic devices. A new photon stop chamber will be used to handle the high synchrotron radiation power generated from the SCWs at high positron beam energy. A 12-m long gate-valve isolated straight sector was created in a second location, where many electron-cloud diagnostic chambers will be installed and tested. We also configured two very short sections in the arcs, with additional gate valves, to provide flexibility of exchanging various meter-long test chambers with minimum impact to the operations. Many retarding field analyzers were integrated into the vacuum modifications in SCWs, dipoles, and drifts to study EC growth and suppression techniques. Creating environments where both local and collaborator provided equipment can be easily installed has been a major objective in the modifications.

INTRODUCTION

At the conclusion of CLEO High-Energy Physics (HEP) program in March 2008, staged modifications were carried out to convert CESR (Cornell Electron Storage Ring) into a test accelerator (aka CEsrTA [1]) for ILC Damping Ring R&D. The motivation of the vacuum system modification is to support the physics programs of CEsrTA, including (1) low-emittance lattice design, tuning and associated beam instrumentations, (2) electron cloud studies and suppression. Another important aspect of the modification is to ensure the continuing successful operations of Cornell High Energy Synchrotron Sources (CHESX) at CESR.

CESR RECONFIGURATIONS

The reconfiguration of CESR was carried out in two major accelerator shutdowns, a three-month down starting in July 2008 and an one-month down in February 2009.

Relocating SCWs to Zero Dispersion Regions

During the CESR-c/CLEO-c HEP program, 12 superconducting wigglers (SCWs) were installed in the south $\frac{1}{3}$ of CESR. As depicted in Fig 1, two triplet SCWs were located at two long straight sections, namely L1 and L5, and the remaining 6 SCWs were in short straight

sections between L0 and L1, and between L0 and L5. During the July 2008 Shutdown, the six SCWs in the short straight sections were relocated at L0 long straight, where the decommissioned CLEO detector and ~17 meters of vacuum chambers were removed. With the relocation, all 12 SCWs are positioned in the long straight sections in which the optics can be configured for zero dispersion, in order to obtain the smallest possible beam emittance. Figure 2 shows the six SCWs going through vacant CLEO detector irons.

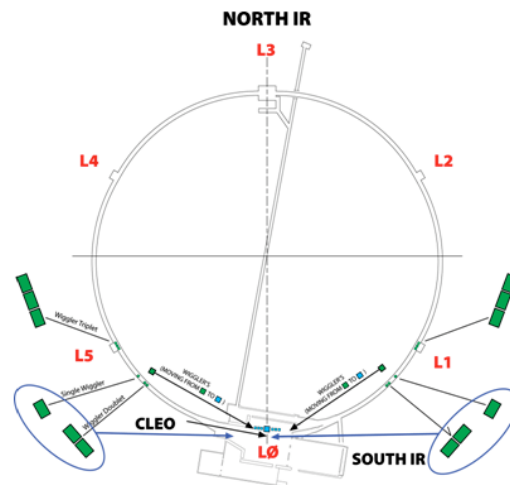

Figure 1. Locations of 12 SCWs (marked as Green boxes) before CEsrTA reconfigurations.

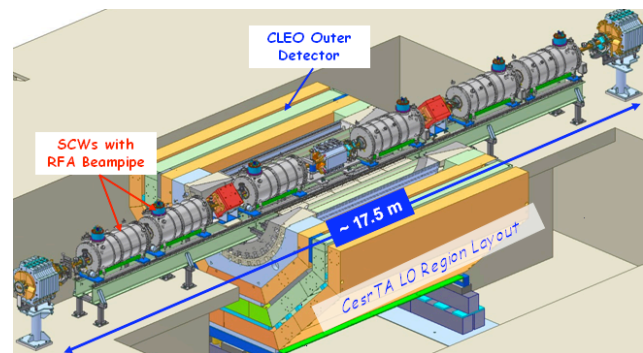

Figure 2. A String of six SCWs was installed in the center of the decommissioned CLEO detector. Two of the SCWs (left) have beampipes equipped with retarding field analyzers.

Experimental areas for Electron Cloud studies

One of objectives in the vacuum system modifications is to create environment where both local and collaborator provided equipment can be easily installed without significant impact to CEsrTA and CHESX operations. Toward this goal, gate valves were added to create four such sections in CESR, mainly for electron cloud (EC) build-up and mitigation studies.

* Work supported by the National Science Foundation and the US Department of Energy
[#]YL67@cornell.edu

In the L0 straight, along with the string of 6 SCWs, many EC diagnostic components, including various retarding field analyzers (RFAs), and pick-up buttons for TE wave measurements [2] were installed.

After removal of a pair of electrostatic vertical separators, another long straight section was established in north region (L3). This 12-meter section, as shown in Fig 3, is currently hosting many SLAC EC study beampipes and diagnostics, including a set of 4-dipole chicane magnets with beampipes equipped with EC detectors, and an aluminum beampipe with grooved interior. A pair of retractable synch-light mirrors (highly polished beryllium) will be used for beam profile measurements. A sample load-lock system was also installed in this section for measurements of secondary electron emission yield (SEY) as a function of synchrotron beam doses for commonly used vacuum chamber materials.

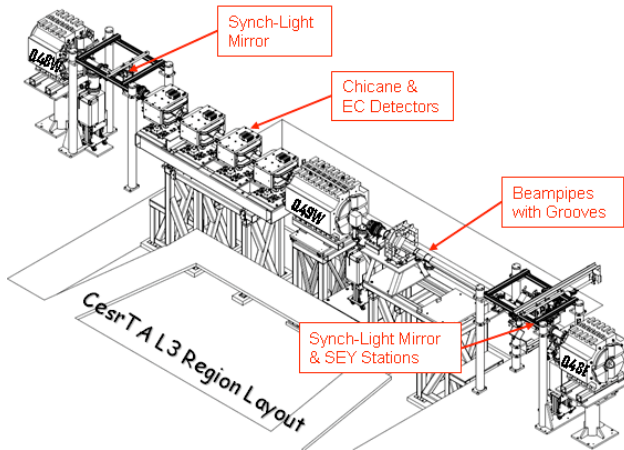

Figure 3. Experimental region at L3 long straight

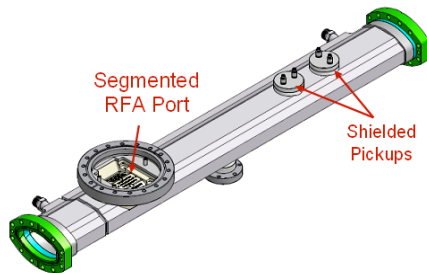

Figure 4. Aluminum chamber for EC suppression tests

We also configured two very short sections in the arcs that had been occupied by SCWs. Unlike the long straight sections at L0 and L3, chambers in these short sections are exposed to intense synchrotron radiation from adjacent bending magnets from beams traveling in both directions. With gate valve isolation, various test beampipes (~ 1m in length) may be replaced in these sections during a scheduled short (<1 day) accelerator down. With intense SR flux, the vacuum chambers in this short section can be quickly conditioned after venting to nitrogen, and thus have very low impact on the accelerator operations. Planned test chambers include

aluminum chambers with segmented RFAs and RF-shielded pick-up buttons that will be used to measure EC suppression with various coating, such as TiN, and α - or diamond-like carbon (shown in Fig 4).

L0 SCW Photon Stopper

As a part of CESR-c/CLEO-c fast luminosity monitor (FLM) system, vacuum chambers in the CESR L0 west region were modified [3] to have an aluminum window with line-of-sight view of electron-positron collision-point (see Fig 5) at CESR L0 center.

With a string of six SCWs relocated in the L0 straight after CesrTA reconfiguration, the FLM aluminum window is subject to intense synchrotron radiation (SR) power generated from the L0 SCW string. A photon stop chamber was designed to handle SCW SR power for a 5 GeV positron beam current up to 100 mA with the 6 wigglers at 2 Tesla. The new photon stop chamber was constructed of OFE copper, with a water-cooled 2.87-m long copper bar forming the outer wall. The angle of the copper bar is design in such a way as to evenly distribute a maximum of 40 kW of SR power over its entire length. An adjacent dipole aluminum bending chamber was also modified to match the new photon stop chamber. Massive titanium sublimation pumping was build into the chamber to handle the SR-induce gas load.

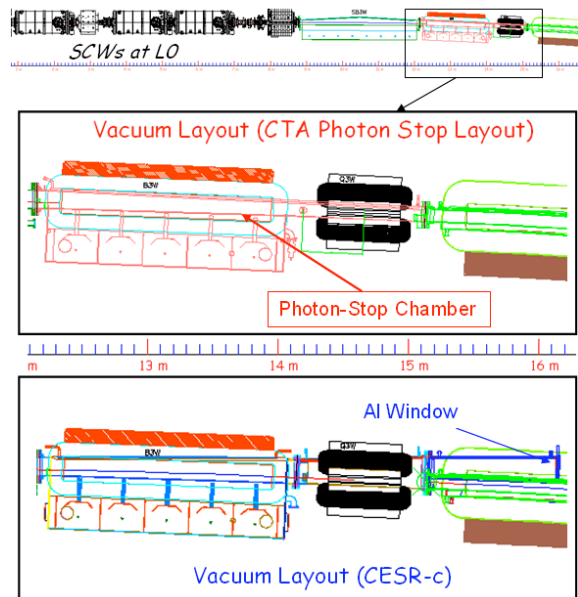

Figure 5. To handle up to 40 kW of SR power from the L0 SCW string, a copper photon stop chamber was installed to replace the aluminum window that was a part CESR-c fast luminosity monitor.

RETARDING FIELD ANALYZERS

Many retarding field analyzers (RFAs) were installed in field-free drift sections and in the fields of various types of magnets. All of these RFAs use precision photo-etched stainless steel meshes as the retarding grid. The mesh has a relatively low transparency (~38%), but it is thick (0.15mm) enough to be self supporting under electrostatic

force. To reduce secondary electron emission on the grids, all meshes were coated with thin gold film.

Flexible printed circuit boards (PCBs) were used as RFA electron collectors. The flexible PCBs were thin Kapton film clad with copper on both sides. Segmented collector pads and connecting leads were patterned on the side facing the grid. With proper cleaning, the Kapton based flexible PCBs were found to be fully UHV compatible.

Insertable RFAs in the field-free drifts

Eight insertable RFAs were installed in the L0 straight section and in the arcs. The structure of the insertable segmented RFA is illustrated in Fig 6.

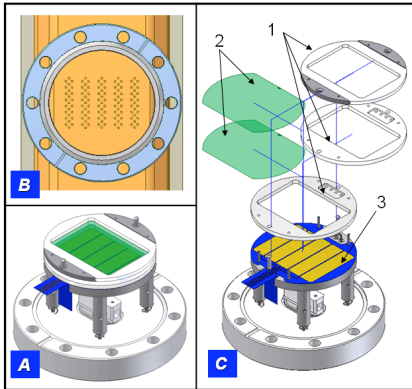

Figure 6. Insertable RFA (A) and RFA port (B) on drift beampipe. Exploded view (C) shows the structure of the RFA: (1) Ceramic spacers, (2) Retarding grid and (3) RFA collector.

Thin RFA on Dipole Chamber

RFAs were implemented on an aluminum bending chamber in a dipole magnet. Due to very limited vertical space available, the entire RFA structure (Fig 7) had to be contained within 2.5mm space, with a weld-on aluminum cover plate.

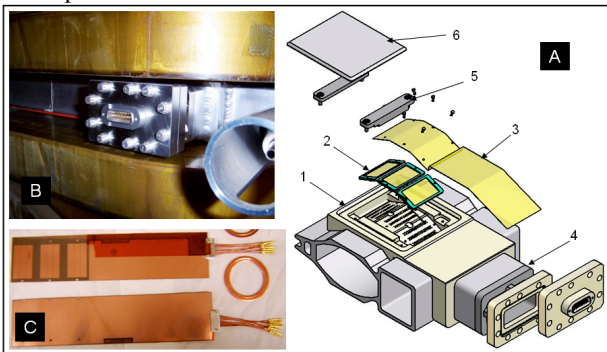

Figure 7. (A) Structure of a thin RFA on bending chamber. 1-RFA housing with electron transmission holes; 2-Retarding grids; 3-Flexible PCB collector; 4-RFA connection port; 5-PCB collector clamps and 6-RFA vacuum cover. (B) RFA dipole chamber installed; (C) Collector pads and back shield plane on the flexible collector.

Thin RFA on SC Wiggler Beampipes

RFAs were deployed in two of SCWs in CESR L0, as indicated in Fig 2. Details of the SCW RFAs are presented in this proceeding. [3]

Thin RFA in quadrupole magnet

Fig 8 shows a design of thin RFAs to be build onto aluminum beampipes going through two large bore quadrupole magnets in the CESR L3 regions namely Q48W and Q48E in Fig 3.

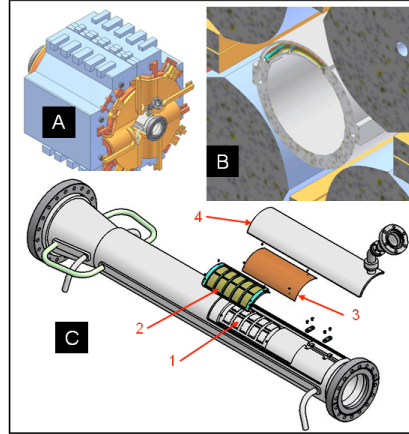

Figure 8. (A) RFA beampipe in quadrupole magnet.; (B) Cross-section at the RFA and (C) RFA components, including: 1-beampipe with 1748 transmission holes; 2-retarding grids; 1-flexible PCB collector and 1-vacuum cover with connection port.

CONCLUSION

We have successfully reconfigured CESR vacuum system over the last year to support the CEsrTA Physics program. The modified vacuum system performs very well. All the installed diagnostics are functioning as expected, and we have started to generate meaningful EC measurement results, with some reported in this proceeding [1].

REFERENCES

- [1] M. Palmer, et al, "The Conversion and Operation of the Cornell Electron Storage Ring as a Test Accelerator (CesrTA) for Damping Rings Research and Development", this proceeding (ID: FR1RAI02)
- [2] S. Santis, et al, "The TE Wave Transmission Method for Electron Cloud Measurements at Cesr-TA", this proceeding (ID: TH5RFP071)
- [3] Y. Li, et al, "Design and Implementation of CesrTA Super-Conducting Wiggler Beampipes with Thin Retarding Field Analyzers", this proceeding (ID: TH5RFP029)