

Design of the CW Cornell ERL Injector Cryomodule*

V. Medjidzade, M. Liepe[†], S. Belomestnykh, R. L. Geng, H. Padamsee, V. Shemelin, and V. Veserevich,
Cornell University, Ithaca, NY, USA

Abstract

The Cornell ERL Prototype injector will accelerate bunches from an electron source to an energy of several MeV, while preserving the ultra-low emittance of the beam. The injector linac will be based on superconducting RF technology with five 2-cell RF cavities operated in cw mode. The beam tubes on one side of the cavities have been enlarged to propagate Higher-Order-Mode power from the cavities to broadband RF ring-absorbers located at 80 K between the cavities. The axial symmetry of these ferrite based absorbers, together with two symmetrically placed input couplers per cavity, avoids transverse on-axis fields, which would cause emittance growth. Each cavity is surrounded by a LHe vessel and equipped with a frequency tuner. The cryomodule provides the support and alignment for the cavity string, the 80 K cooling of the ferrite loads, and the 2K LHe cryogenic system for the high cw heat load of the cavities. In this paper we give an overview of the ERL injector cryomodule design.

INTRODUCTION

Cornell University's Laboratory for Elementary-Particle Physics (LEPP) is exploring the potential of a light source based on an Energy-Recovery-Linac (ERL) [1]. One attractive feature of a future ERL-based light source is the low emittance beam from a high-brightness photo-emission electron gun. But several accelerator physics and technology issues need to be explored, before a full energy ERL light source can be built. One of the main challenges is the production and preservation of the low emittance beam in the injector. In the injector, a bunched 100 mA, 500 keV beam of a DC gun will be compressed in a normal-conducting copper buncher and subsequently accelerated by five superconducting (SC) 2-cell cavities to an energy of 5.5 MeV. To explore whether higher injector beam energy is favorable, the injector cavities will also be operated at three times the nominal gradient to deliver 15 MV total, but at lower current. Table 1 lists additional injector beam parameters. As a first stage, Cornell University will build the injector section to study the production of the ultra-low emittance beam in detail [2, 3]. One of the main components of the injector is its cryomodule with five superconducting 2-cell cavities. The injector RF system needs to deliver 500 kW to the beam through input coupling devices, while removing more than 100 W of beam induced higher-order mode (HOM) power through HOM absorbers. At the same time emittance preservation is essential. The

Table 1: Injector beam parameters.

| | |
|--|-------------------------|
| Max. current ($Q_{bunch} = 77$ pC) | 100 mA |
| Max. current ($Q_{bunch} \approx 1$ nC) | 1 mA |
| Max. bunch rep. rate | 1.3 GHz |
| Emittance ($Q_{bunch} = 77$ pC) | $< 0.5 \mu\text{m rad}$ |
| Max. emittance growth ($Q_b = 77$ pC) | $< 0.1 \mu\text{m rad}$ |
| Bunch length | < 1 mm |
| Max. beam energy at end (100 mA) | 5.5 MeV |
| Max. beam energy at end (33 mA) | 15.5 MeV |

CW Cornell ERL Injector Cryomodule has been designed to fulfill these demanding tasks.

2-CELL CAVITIES

The design of the superconducting 1.3 GHz 2-cell cavities has been adopted from the 500 MHz CESR [4] and KEK-B [5] cavities. The beam tube on one side of the cavity is enlarged to propagate out higher-order modes (HOMs) [6]. With the cavity shape proposed, even the lowest dipole mode propagates into the beam pipe where it can be adequately damped by ferrite absorbers lining the beam pipe. The frequencies of all dipole and HOM monopole modes are at least 10 MHz higher than the appropriate cut-off frequency of the beam pipe. Two copper models of the 2-cell cavity have been built and verified this. Strong HOM damping can be achieved this way, and guarantees good emittance preservation. Figure 1 shows the first copper model of the cavity. Table 2 lists properties of the 2-cell niobium structure. The production of the first niobium cavity has started, and first test results are expected for early fall this year. The progress on the cavity production is fully discussed in [7].

Beside insufficient HOM damping, two more cavity related effects can cause emittance growth: cavity misalignment and transverse coupler kick fields. In the ERL injector cavity design this is addressed by tight alignment tolerances (0.5 mm transverse), and a twin coaxial coupler; see Figure 1. Special care is taken in the cavity production to achieve tight tolerances [7]. The twin coaxial coupler [8] for the 2-cell SC cavities offers two advantages: (1) Ideally there is zero transverse kick to the beam traveling along the cavity axis and (2) it reduces the power load for each of its arms by a factor of two. HOM couplers are avoided completely in the ERL injector cryomodule to eliminate related kick fields and resulting emittance dilution.

* Work supported by NSF.

[†] mul2@cornell.edu

Table 2: Properties of the 2-cell ERL injector cavity.

| | |
|--------------------------------|--------------------------------------|
| Frequency | 1.3 GHz |
| Number of cells | 2 |
| R/Q | 218 Ω |
| E_{pk}/E_{acc} | 1.94 |
| H_{pk}/E_{acc} | 42.8 Oe/(MV/m) |
| Cell to cell coupling | 0.7 % |
| Max. transverse offset | 0.5 mm |
| Max. cavity tilt | 1 mrad |
| Q_0 at 2 K | $> 10^{10}$ |
| Q_L | $4.6 \cdot 10^4$ to $4.1 \cdot 10^5$ |
| Accelerating voltage | 1 to 3 MV |
| Max. power transferred to beam | 100 kW |

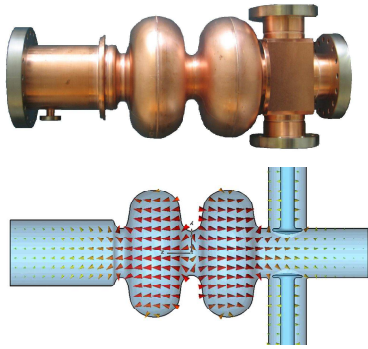

Figure 1: ERL injector cavity. Top: Copper prototype. Bottom: Geometry of the cavity with the fundamental mode exited in it.

INPUT COUPLER

In the injector cavities, a high average RF power must be coupled to a vulnerable low-energy beam. Beside the input coupler challenges resulting from the high power handling, the other major challenge is to not disturb the beam. A twin coaxial coupler design reduces harmful transverse kick fields ideally to zero (on-axis). The geometry and location of the antenna tip is optimized to minimize penetration into the beam pipe. Even for a one mm offset between the two antenna locations, the kick is still more than a factor of 10 lower than the kick produced by a single coupler. A full description of the coupler is presented in [9]. Table 3 lists main parameters of the ERL injector input coupler. The mechanical and electrical designs have been finished, see Figure 2. RF heating and required cooling has been studied in detail [10]. Air flow through the inner conductor will be used to intercept RF heating on the inner warm bellows. The manufacturing of two prototype couplers will be finished early next year, followed by RF tests under full load.

HOM ABSORBER

As aforementioned, strong damping of the HOMs is essential to preserve beam emittance and to reduce the total

Table 3: Properties of injector input coupler.

| | |
|---------------------------|--------------------------------------|
| Frequency | 1.3 GHz |
| Bandwidth | ± 10 MHz |
| Max. cw traveling power | 75 kW |
| Number of windows | 2 |
| Coaxial line OD | 62 mm |
| Cold coax. line impedance | 60 Ω |
| Q_{ext} range | $9.2 \cdot 10^4$ to $8.2 \cdot 10^5$ |

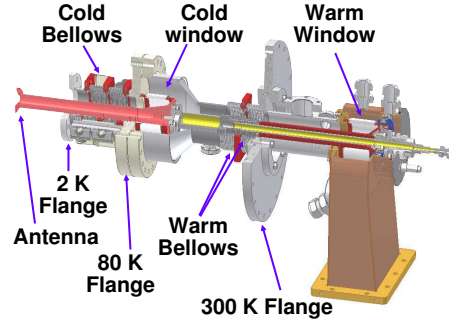

Figure 2: ERL injector input coupler (mechanical design).

HOM losses. Quality values between a few 100 and a few 1000 are required. To achieve this demanding goal we plan to place RF absorbing material in the beam tubes between the cavities in the linac [11]. However, this will require operating the HOM absorbers at temperatures below 80 K to simplify the thermal transition to the cavities at 2 K with low static losses to 2 K. A combination of three different RF absorbing materials has been identified to guarantee efficient RF absorption starting at 1.4 GHz and going beyond 50 GHz [12]. Table 4 lists parameters of the HOM absorber. The mechanical design has been finished; see Figure 3. A massive coupler block with helium gas flowing through channels will be used to intercept the absorbed RF power. Brazing tests of the RF absorbing material have been started. A first prototype will be tested next year.

Table 4: Properties of the HOM absorber.

| | |
|--------------------------|--------------------------------|
| Average HOM loss /cavity | 26 W |
| Max. power per absorber | 200 W |
| HOM frequency range | 1.4 to > 50 GHz |
| Operating temperature | 80 K |
| Coolant | GHe |
| Absorber type | TT2-111R, HexMZ, ZRC10CB5 [12] |

FREQUENCY TUNER

The frequency tuner for the 2-cell ERL injector cavities has been adopted from the DESY/INFN blade tuner design [13]. While fast microphonics compensation is not required in the ERL injector (the loaded Q of the cavities is low), it will be highly beneficial in the ERL main linac

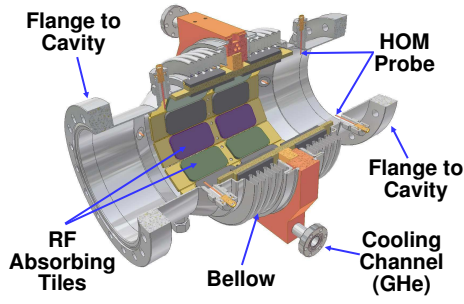

Figure 3: ERL injector HOM RF absorber (mechanical design).

with its high loaded Q cavities. In order to study the potential of active microphonics compensation with the ERL injector cryostat, short piezo-electric actuators have been integrated in the frequency tuner mechanism. Table 5 lists some parameters of the frequency tuner. The blade design with its mechanism and driving motor can be seen in Figure 4. A first prototype is planned to be built by early next year.

Table 5: Properties of the frequency tuner.

| | |
|----------------------|---------------------|
| Tuning range (motor) | ± 400 kHz |
| Resolution (motor) | ≈ 1 Hz/step |
| Tuning range (piezo) | ± 200 Hz |

CRYOMODULE

The design of the injector cryomodule will follow the design of the TTF cryomodule [14]. There will be a simplified heat intercept at 4.2 K (cold He gas) and a thermal shield at 80 K (cold He gas). Cryogenic piping in the cryomodule has been adjusted for the increased 2 K head load. Presently we are working on a design which will allow a simplified alignment of the beam line components. Figure 4 shows a section of the cold mass of the injector cryomodule. As in the TTF module design, the cavities are supported from the large helium gas return pipe. The end sections of the cryomodule have been redesigned to allow for short transition to room temperature. Some preliminary parameters of the injector cryomodule are listed in Table 6.

Table 6: Properties of the cryomodule.

| | |
|----------------------|-----------------|
| Number of cavities | 5 |
| Number of HOM loads | 6 |
| Overall length | ≈ 5.4 m |
| Total max. 2 K load | ≈ 25 W |
| Total max. 5 K load | ≈ 70 W |
| Total max. 80 K load | ≈ 700 W |

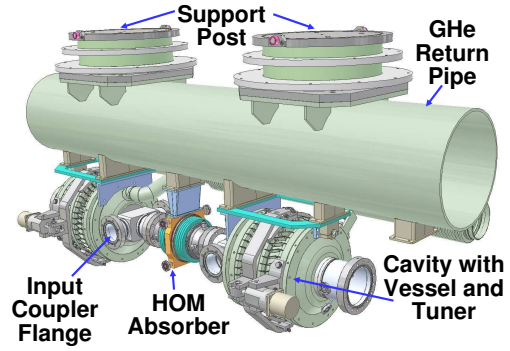

Figure 4: Two cavity section of the cold mass of the ERL injector cryomodule (mechanical design).

REFERENCES

- [1] G. Hoffstaetter et al., this conference, paper RPPT026.
- [2] Study for a proposed Phase I Energy Recovery Linac (ERL) Synchrotron Light Source at Cornell University, ed. by S. Gruner and M. Tigner, CHSS Technical Memo 01-003 and JLAB-ACT-01-04 (2001).
- [3] G. Hoffstaetter et al., "The Cornell ERL Prototype Project", Proceedings of the 2003 Particle Accelerator Conference, Portland, Or, USA (2003).
- [4] H. Padamsee et al., "Accelerating Cavity Development for the Cornell B-Factor, CESR-B", Proceedings of the 1991 Particle Accelerator Conference, Chicago, Il, USA (1991).
- [5] S. Mitsunobu et al., "Superconducting RF Activities at KEK", Proceedings of the 5th Workshop on RF Superconductivity, Hamburg, Germany, 1991, pp. 84-94 (1991).
- [6] V. Shemelin et al., "Dipole-Mode-Free and Kick-Free 2-Cell Cavity for the SC ERL Injector", Proceedings of the 2003 Particle Accelerator Conference, Portland, Or, USA (2003).
- [7] R.L. Geng et al., this conference.
- [8] S. Belomestnykh, et al., "High Average Power Fundamental Input Couplers for the Cornell University ERL: Requirements, Design Challenges and First Ideas", Cornell LEPP Report ERL 02-8 (2002).
- [9] S. Belomestnykh, et al., "Development of High RF Power Delivery System for 1300 MHz Superconducting Cavities of Cornell ERL Injector", Proceedings of LINAC'2004, Luebeck, Germany, pp.694-696 (2004).
- [10] N.P. Sobenin et al., "Thermal Calculations of Input Couplers for the Cornell ERL Injector Cavities", to be published in the Proceedings of RUPAC-204, Dubna, Russia (2004).
- [11] M. Liepe et al., "First Studies for a Low Temperature Higher-Order-Mode Absorber for the Cornell ERL Prototype", Proceedings of the 2003 Particle Accelerator Conference, Portland, Or, USA (2003).
- [12] V. Shemelin et al., this conference.
- [13] C. Pagani, "SRF Activities at INFN Milano - Lasa", Proceedings of the 10th Workshop of RF Superconductivity, Tsukuba, Japan (2001).
- [14] C. Pagani et al., "Further Improvements of the TESLA Test Facility Cryostat in View of the TESLA Collider", Advances in Cryogenic Engineering, Vol. 45A, Edited by Q-S. Shu, Plenum Press, New York (1999).