

OPERATING EXPERIENCE WITH $\beta = 1$ HIGH CURRENT ACCELERATORS*

S. Belomestnykh[#]

Laboratory for Elementary-Particle Physics
Cornell University, Ithaca, NY 14853, USA

Abstract

Using superconducting cavities proved to be a reliable and efficient way to provide RF power to high-current, high-energy beams. Significant operating experience was accumulated in recent years in running superconducting cavities in electron-positron colliders CESR and KEKB. Recent results are reviewed. Successful operation of these machines as well as of accelerators of an older generation like LEP, TRISTAN and HERA made superconducting RF the technology of choice for many other high-current colliders (BEPCII, LHC) and light sources (CLS, DIAMOND, SOLEIL, TLS). A full set of superconducting cavities for LHC has already been manufactured and tested. The first cryomodule for SOLEIL was fabricated, tested on a test stand at CERN and recently subjected to a beam test at ESRF. The first CLS cryomodule has been commissioned without a beam. Results of those tests are discussed. Another trend in recent years is the use of beam-driven (passive) superconducting cavities for bunch length manipulation. Harmonic cavities are commonly used for this purpose. In the collider mode of operation bunch shortening enhances luminosity. Recent experimental results with fundamental RF harmonic cavities at CESR-c are presented. In the light source mode of operation bunch lengthening improves beam lifetime and raises coupled-bunch instability thresholds as it is shown by experience with third-harmonic cavities at SLS and ELETTRA. BESSY-II plans to use a third-harmonic passive superconducting cavity for bunch lengthening as well.

INTRODUCTION

This paper reviews operating experience with superconducting RF (SRF) systems at contemporary high-current (>100 mA), high-energy ($\beta = 1$) accelerator facilities. Existing accelerators that satisfy this definition are storage rings. They are used as precise instruments at the forefront of two scientific fields: i) colliders serve as instruments to study the structure of matter on the very fundamental level (high-energy or elementary-particle physics) and ii) light sources generate brilliant x-rays (synchrotron radiation) for various experiments to investigate the detailed atomic structure of solids and liquids in both biological and non-biological systems.

“Traditional” application of superconducting cavities in such machines is fundamental RF systems for high-energy

physics (HEP) colliders such as CESR [1] and KEKB [2]. Whereas early SRF applications to HEP colliders HERA [3], LEP [4] and TRISTAN [5] employed multi-cell structures, increased beam current of “factories” necessitated development of single-cell HOM-damped cavities [6]. Advantages of superconducting cavities [7] and successful and reliable operation of SRF cavities in CESR and KEKB encouraged other laboratories to consider SRF for their future projects. Many new high-current colliders [8, 9] and light sources [10, 11, 12, 13] plan to use single-cell HOM-damped SRF systems. And though none of those new systems is yet in operation, there is progress in developing, testing and commissioning.

Parameters of an RF system along with some other accelerator parameters determine the bunch length. In some cases it is desirable to manipulate bunch length by means other than the fundamental RF cavities driven by an RF power generator. For example, to improve Touschek beam lifetime in light sources, one can increase bunch length by using harmonic superconducting cavities in beam-driven (passive) mode of operation [14]. This was successfully done in Swiss Light Source (SLS) [15] and ELETTRA [16].

With the technology transfer to industry [17] and close inter-laboratory collaboration [18] SRF has become the technology of choice for fundamental RF systems and for bunch length manipulation cavities of many new accelerators. For each of these two categories we will review operating experience in existing machines, recent test results, and future projects.

FUNDAMENTAL RF SYSTEMS

Table 1 lists machine and RF system parameters for the fundamental SRF system in operation or under construction. One can see that cavities operate at moderate accelerating fields: from 2.8 MV/m (SOLEIL) to 8 MV/m (CLS). Two major challenges for superconducting cavities in high current storage rings are: i) sufficiently damp HOMs and ii) ability to deliver high beam power. As we will see below, different designs approach those challenges in different ways.

Systems in Operation: CESR and KEKB

Two superconducting-cavity-based fundamental RF systems currently in operation are those in CESR and in the high-energy ring (HER) of the KEK B-factory. Both systems use cavities made of bulk niobium and, because

*Work is supported by the National Science Foundation.

[#]sab@lepp.cornell.edu

they were designed for high-current, high-luminosity colliders, they have many common features.

Table 1: Parameters of fundamental SRF systems (parameters for CESR-III and KEKB are operationally achieved, all others are design specifications).

	CESR-III	CESR-c	KEKB	LHC	BEPC-II	SOLEIL	TLS	CLS	DIAMOND
Machine mode of operation	Single-ring collider / light source	Single-ring collider	HER of two-ring collider	Two-ring collider	Two-ring collider / light source	Light source	Light source	Light source	Light source
Beam energy [GeV]	4.7...5.6	1.55...2.5	8	7000	1.0...2.0 / 2.5	2.75	1.5	2.5 / 2.9	3.0
Beam current [mA]	780	260...460	1100	2×560	2×910 / 250	500	500	500 / 280	300 (500)
Frequency [MHz]	500	500	509	400	500	352	500	500	500
R/Q [Ohm]	89	89	93	89	95.3	90	89	89	89
Q_{ext}	2×10 ⁵	2×10 ⁵	7×10 ⁴	2×10 ⁴ ... 3.5×10 ⁵	1.7×10 ⁵	1×10 ⁵	2×10 ⁵	2×10 ⁵	2×10 ⁵
Cavity voltage [MV]	1.6...2.0	1.85...3.0	1.2...2.0	2	1.5	1.2	1.6	2.4	2.0
Number of cavities	4	4	8	2×8	2×1 / 2	4	1	1	2 (3)
RF power per coupler [kW]	300 (360)	40...160	380	116 (176)	122 / 96	200	82	245	280 (300)
Cavity	CESR B-cell	CESR B-cell	KEKB	LHC	KEKB	SOLEIL	CESR B-cell	CESR B-cell	CESR B-cell
RF coupler	Waveguide	Waveguide	Coax	Coax variable	Coax	Coax	Waveguide	Waveguide	Waveguide

The CESR RF system consists of four B-cell cavity cryomodules [19] shown in Figure 1. The cavity [20] has large beam pipes. The beam pipe on one side is round with the diameter of 240 mm. It allows all but two lowest dipole modes (607 MHz and 650 MHz) to escape from the cell. The other beam pipe has additional “flutes”, which lower the TE₁₁ cut-off frequency to 570 MHz and thus permit the lowest modes to propagate out of the cavity. Two ferrite loads [21], connected to the cryomodule on both sides, absorb the HOM power. The loads (Figure 2) have modular design with ferrite tiles soldered to water-cooled plates. Fundamental RF power is coupled to the cavity via a coupling slot between the rectangular waveguide and the round beam tube next to the cell. An alumina ceramic window separates evacuated waveguide inside the cryomodule and air-filled waveguide transmission line connecting the cavity to a klystron.

The beam test of a prototype cryomodule was performed in 1994 [22]. This was the first demonstration of high current operation for superconducting cavities. First cryomodule was installed in CESR for routine

operation in 1997. With subsequent installations of three more cryomodules, CESR became the first storage ring in the world to run entirely on superconducting cavities.

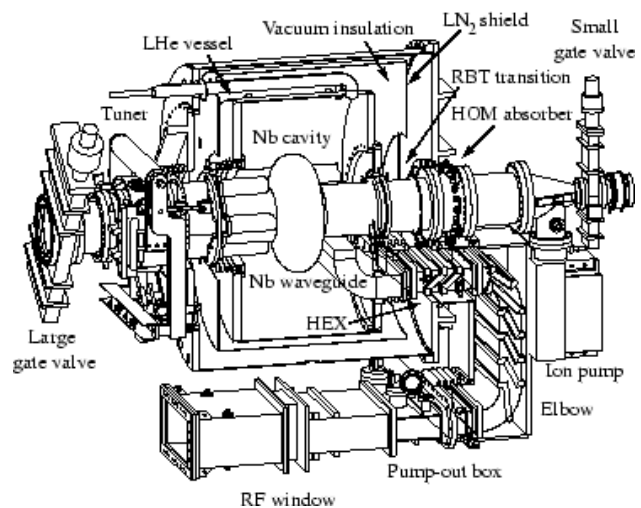

Figure 1: Cornell B-cell cryomodule.

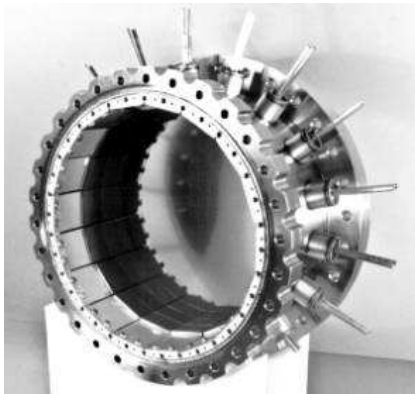

Figure 2: Ferrite HOM load.

Until recently CESR ran as an HEP collider CESR-III at energies of different Y resonances with synchrotron radiation user facility operating in a time-sharing mode. This operation was very demanding in terms of total beam current and beam power. With SRF system in place, CESR-III was able to store 780 mA total beam current and achieve peak luminosity of $1.3 \times 10^{33} \text{ cm}^{-2} \text{ s}^{-1}$ [23]. Cavities operated at an average voltage of 1.85 MV. Maximum power delivered to beam was 300 kW with maximum forward power of 360 kW. Quality factor measured in CESR stays above 10^9 up to 2 MV and then begins to fall down to $(0.3 \dots 1) \times 10^9$ at 2.7 MV (Figure 3).

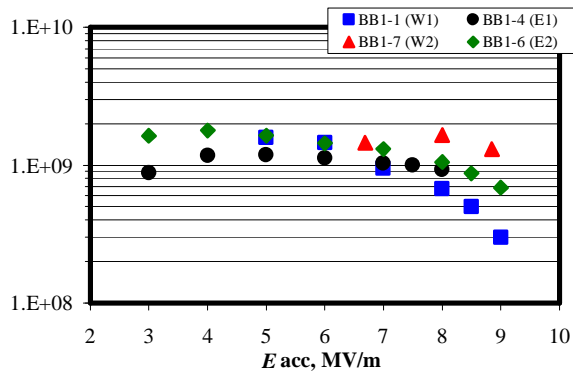

Figure 3: Q vs. E_{acc} for CESR cavities.

In 2003 CESR facility began operation in a new mode, alternating HEP runs in the tau/charm energy range (1.55 to 2.5 GeV) as CESR-c [24] with synchrotron light source runs at 5.3 GeV as CESR-CHESS. CESR-CHESS operational requirements are similar to CESR-III, but somewhat relaxed with maximum beam current of 500 mA. CESR-c operation is radically different for RF system as the emphasis is not on delivering very high RF power to beams, but on providing very high RF voltage to produce short bunch length and high synchrotron tune [25]. RF power required for CESR-c is very moderate: 40 to 160 kW depending on the energy of the experiment.

KEKB HER RF system consists of 8 SRF cryomodules (Figure 4) and 12 normal conducting ARES cavities [2]. KEBK SC cavities have design features similar to CESR B-cell cavities, but implementations are different. A larger diameter round beam tube, rather than fluted beam

tube, separated from the cell by an iris, is used to deal with the lowest dipole modes. The Hot Isostatic Press (HIP) sinter-bonding method is used to fabricate beam-line ferrite HOM absorbers [26]. The fixed coaxial antenna coupler couples input RF power to the cell [27].

The beam test of the KEBK cryomodule took place in the TRISTAN AR in 1996 [28]. The first four cavities were installed in KEBK HER in 1998, four more cavities were added in 2000. Operation of superconducting cavities in HER is very stable and reliable. The following performance has been achieved to date [29]: the maximum stored beam current of 1.1 A, peak luminosity of $1.06 \times 10^{35} \text{ cm}^{-2} \text{ s}^{-1}$ (world record). The cavities operate at an average voltage of 1.2 MV (with one cavity running at 2 MV). The maximum power delivered to beam is 380 kW (another world record). Up to 10 kW of HOM power per cavity is absorbed in ferrite dampers (Figure 5).

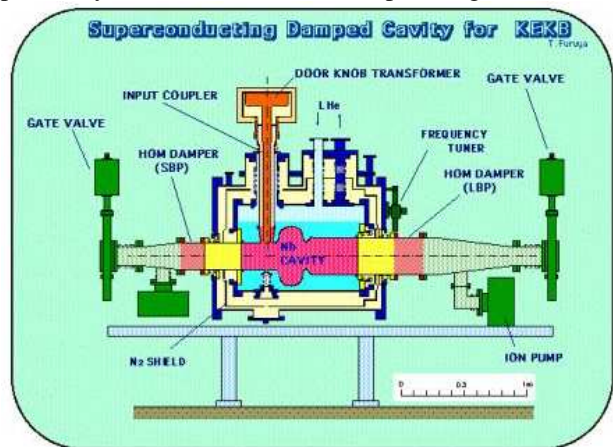

Figure 4: KEBK HER cryomodule. (Courtesy of T. Furuya, KEK.)

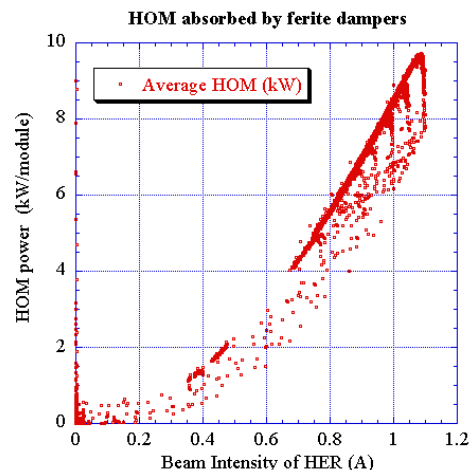

Figure 5: HOM power in KEBK SC cavity. (Courtesy of T. Furuya, KEK.)

SOLEIL Cryomodule Beam Test at ESRF

SOLEIL is a 2.75 GeV, 500 mA future light source to be built in France. For RF system cavities it adopted niobium-sputtered-on-copper technology developed at CERN for LEP collider. Two 352 MHz single-cell

cavities in a cryomodule [30] are connected by a large tube of 400 mm diameter (Figure 6). Four loop couplers, rather than beam-line ferrite absorbers, are installed between the cavities to damp HOMs. Coaxial LEP-type couplers are used for fundamental RF. The prototype cryomodule was designed, built and tested by Saclay/CERN collaboration [31]. The cryomodule had reached accelerating gradient of 7 MV/m.

In December 2001 the prototype was installed in the ESRF storage ring for a beam test [32]. Four tests with cavities at 4 K were carried out in 2002. Dewars were used to supply liquid helium to the cryostat. The cavities were warmed up to room temperature between the tests. 200 mA beam current was stored with cavities detuned (both at room temperature and at liquid helium temperature) with no sign of HOM-driven instability. The cryomodule was reconditioned to 4 MV in CW and 5 MV in pulsed mode. After that, 170 mA beam could be stored

with SOLEIL cavities supplying 3 MV of accelerating voltage out of total 7 MV. This corresponds to 360 kW of power transferred by SC cryomodule.

The test was extremely successful in validating the concept and achieving RF voltage and power requirements of SOLEIL. It allowed to identify a few improvements that will have to be made before the cryomodule installation and commissioning. Among them are: installation of the liquid nitrogen radiation shielding to reduce large static heat loss of 117 W; improvement of the dipole HOM coupler design; change of external quality factor from 2.2×10^5 to 1×10^5 . The plan is to complete refurbishing of the first unit by October 2004 to allow SOLEIL commissioning in spring of 2005. The second unit should be ready for installation by the end of 2005.

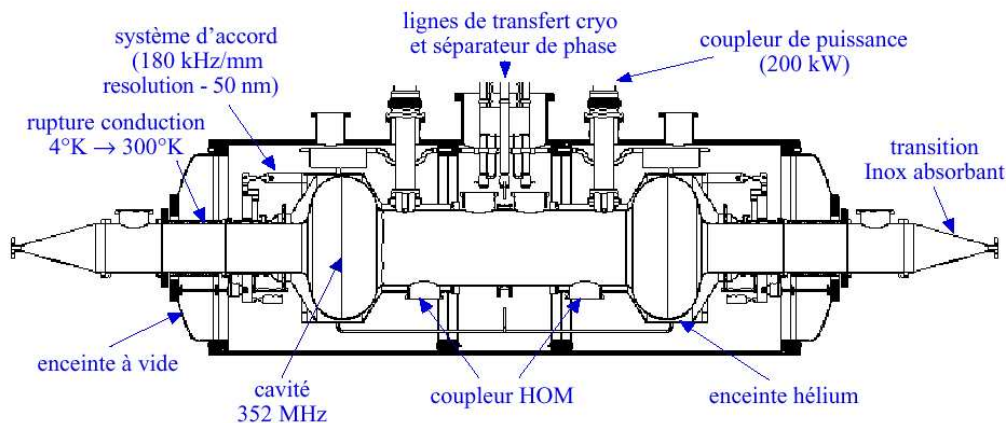

Figure 6: SOLEIL cryomodule [30].

Progress Toward the Superconducting RF for LHC

LHC is a 7 TeV hadron collider under construction in the LEP tunnel at CERN. Two 560 mA proton beams will circulate in separate vacuum chambers, accelerated by 8 single-cell 400 MHz superconducting cavities each [8]. The cavities are combined in fours in the cryostats (Figure 7). Each cavity will deliver 2 MV of RF voltage and 116 kW (176 kW during injection) of RF power to the beam. Having different modes of operation at injection (full beam compensation) and storage (minimum power) necessitates a variable coupler to optimize each mode.

21 niobium-film-on-copper cavities were produced, all of them performing better than specified [33]. Five cryomodules (four for operation and one spare) are assembled and were tested at low power. The cryomodules are ready to receive the last component, the input power coupler. The first cryomodule was tested with four prototype input couplers up to the nominal power (300 kW) in 2001. Though successful, the test showed that some details had to be changed on the coupler to improve reliability. The first four improved couplers have been mounted and baked out on the first

module and are ready for conditioning. The last module should be ready by 2005 and installation should begin in 2006.

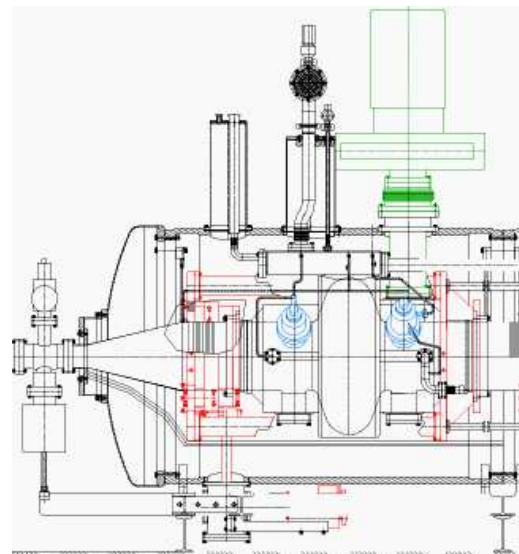

Figure 7: Partial view of the LHC cryomodule [8].

Industrial Production of SRF Systems for Future Storage Ring Based Light Sources

Successful and reliable operation of the first SRF systems for high current beams stimulated interest of other laboratories and industry to this technology, especially in application to the third generation light sources. As these relatively small new user facilities are built very often on a “green site”, they have limited infrastructure and capabilities of doing accelerator related R&D and often lack of expertise in superconducting RF. The main stopping points in adopting new technology for many of them were reluctance to invest significant amount of resources in R&D and infrastructure and desire to purchase ready-to-use products from industry. The turning point in the attitude toward superconducting RF came in 2000 when Cornell University and ACCEL pioneered in concluding the technology transfer agreement for industrial production of CESR B-cell cryomodules and SRRC in Taiwan became the first laboratory to order two turn-key superconducting accelerator modules for the Taiwan Light Source (TLS) upgrade [34]. Later on Canadian Light Source (CLS) and DIAMOND facility in UK followed the suit.

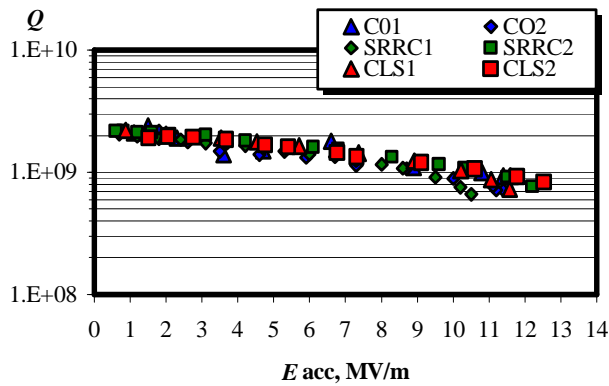

Figure 8: Vertical test results of ACCEL produced cavities.

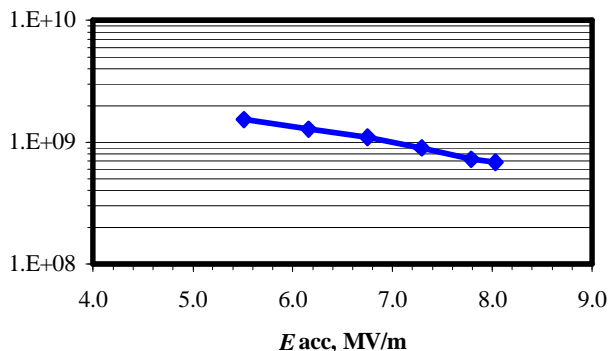

Figure 9: Q vs. E_{acc} of CLS cryomodule #1. (Courtesy of M. Pekeler, ACCEL.)

Six cavities (two each for Cornell, SRRC and CLS) were fabricated by ACCEL so far and tested in a vertical cryostat at Cornell with very good, reproducible results (Figure 8). Two cryomodules for CESR have been delivered to Cornell, commissioned and are in operation.

The first turn-key cryomodule has been complete and recently commissioned at CLS [35]. It reached 12 MV/m in pulsed mode and the specified value of 8 MV/m in CW operation (Figure 9). No quenches were observed during processing or CW operation. The high power test of the first cryomodule for TLS resulted in RF window failure. This cryomodule is now being repaired and will be re-tested later.

Superconducting RF System for BEPC Upgrade

BEPC-II, an upgrade of the BEPC collider, is a future machine, which will operate in two regimes: as a two-ring collider or as a single-ring synchrotron radiation source. Based on the feasibility study [9], the single-cell superconducting cavities were chosen. One cavity per ring will provide voltage of 1.5 MV to 910 mA, 1.89 GeV beam in the collider regime. Two cavities will support beam current of 250 mA at 2.5 GeV or 150 mA at 2.8 GeV in the light source mode of operation. It was announced recently that KEKB SC cavity design will be used for BEPC-II RF system and that system development will be in close cooperation with KEK.

SC CAVITIES FOR BUNCH LENGTH MANIPULATION

Having ability to manipulate bunch length may significantly improve performance of high current storage rings. In low to medium energy storage ring light sources, the beam lifetime is usually dominated by the Touschek effect (large-angle intra-beam scattering). One can improve the Touschek lifetime by increasing momentum acceptance and/or reducing bunch charge density. A particularly attractive option is to lengthen bunches by using harmonic RF cavities [36]. When appropriately phased harmonic voltage is applied, there is an increase in the spread of synchrotron frequencies within the bunch. This big spread increases damping of the longitudinal coupled-bunch instabilities (so-called Landau damping). In colliders, it is important for the bunch length to match the beta-function at the interaction point to avoid luminosity decrease by an “hour-glass” effect. In this case short bunches are required and can be obtained by adjusting the phase of the harmonic cavity voltage. The voltage in the harmonic cavity is generated either by an external generator (active cavity) or by the beam itself (passive cavity).

Until recently only normal-conducting cavities were used for bunch length manipulation. However, superconducting cavities, due to very high Q factor and lower R/Q , have certain advantages in addition to usual advantages of SRF systems. Among those additional advantages are: negligible beam energy loss; operating far from resonance, where the harmonic phase is close to optimum; less sensitivity to an ion cleaning gap. Because of this, the passive cavity operation is often sufficient. Two third harmonic superconducting cavity systems were recently brought to operation: one at SLS and one at ELETTRA. Table 2 lists accelerator and cavity

parameters for machines with SC cavities for bunch length manipulation. All listed cavities are used in the beam-driven accelerating mode.

Table 2: SC cavities for bunch length manipulation.

	CESR-c	ELETTRA	SLS	BESSY-II
Machine type	Single-ring collider	Light source	Light source	Light source
Beam energy [GeV]	1.55...2.5	2 (2.4)	2.4	1.7
Beam current [mA]	260...460	300 (140)	400	250
Resonant frequency [MHz]	500	1500	1500	1500
Harmonic of RF frequency	1	3	3	3
Cavity voltage [MV]	1.85...3	0.3	0.4	0.5
Number of passive cavities	2	2	2	1
Bunch lengthening /shortening factor	1.41	3	3	-
Cavity type	CESR B-cell	Scaled SOLEIL	Scaled SOLEIL	Scaled CESR B-cell

SUPER-3HC Project and Operating Experience at SLS and ELETTRA

Two third generation light sources, ELETTRA and SLS, having similar requirements, joined their efforts in developing a third harmonic RF system for bunch lengthening. As the most attractive, they chose an idle superconducting cavity option. The system is based on the SOLEIL two-cavity cryomodule design scaled to 1.5 GHz [18]. In October 1999 Synchrotron Trieste, PSI and CEA-DAPHNIA Saclay signed a collaboration agreement on the SUPER-3HC Project with the objective to design and produce two complete cryomodules, one for ELETTRA and one for SLS.

Sputtered Nb/Cu cavities were made by CERN and were tested there in a vertical cryostat. Then the cavities were transported to Saclay, where they were assembled in cryomodules (Figure 10) and tested. Both cryomodules exceeded their design goal of Q factor of 10^8 at accelerating gradient of 5 MV/m and temperature of 4.5 K [37].

The first cryomodule was installed in the SLS ring in June 2002. Initially the cavities were kept at room temperature and detuned. Helium gas was circulated through the cryostat for cooling. However, the beam current was limited to 200 mA due to cryomodule overheating. Cold operation started on October 1, immediately after cool-down. With the cavity detuned, the beam current limit was still 200 mA because of excitation of a coupled-bunch mode instability correlated with a higher-order mode of the main RF system. As expected, Landau damping with the cavities at nominal voltage suppressed the instability and it was possible to

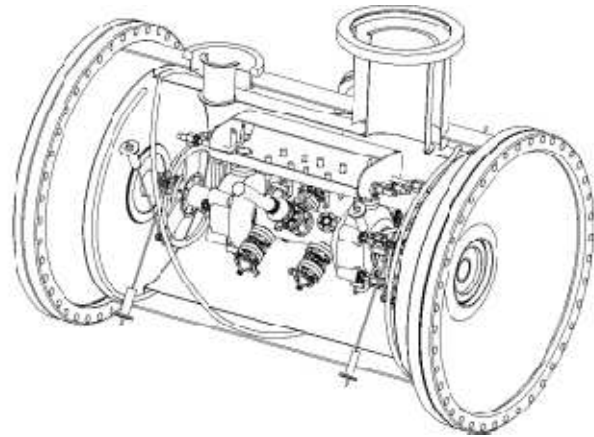

Figure 10: 3D view of the S3HC cryomodule [37].

raise the current to 400 mA. Stable operation at the maximum beam current was demonstrated with lifetime about two times longer than the predicted lifetime without harmonic cavities. At 180 mA bunch elongation factor of 3 was measured at the voltage of 0.69 MV with corresponding improvement of the lifetime by a factor of 2.2. The SLS cryomodule is the first demonstration of a superconducting Landau cavity in a light source [15].

The ELETTRA cryomodule was installed in the accelerator during the summer of 2002. While the cryogenic system was commissioned in October – December 2002, the cavities remained at room temperature in a detuned position. Because of cavity overheating by the 320 mA beam at 2.0 GeV (nominal mode of operation), it was necessary to operate at 2.4 GeV and 140 mA until January 2003, when the cold cavity operation began. After overcoming some problems during the commissioning period, the routine operation

started in July 2003 [16]. No negative effect of the cavity HOMs was observed on the 320 mA beam at 2.0 GeV and during injection at 0.9 GeV. Before the third harmonic cavity installation ELETTRA operated with a controlled excitation of a longitudinal coupled-bunch mode. Tuning the superconducting harmonic cavity for bunch lengthening stabilizes the beam. Other achievements are: bunch lengthening factor of about 3 and the beam lifetime of 26.7 hours or 3.5 times the theoretical value.

Passive Cavities for CESR-c

While the high RF voltage is required to produce short bunch length and high synchrotron tune in CESR-c, the beam power demand is very modest and does not justify using three transmitters as in the present RF system configuration [25]. Even one klystron is more than adequate to supply necessary power. To significantly reduce RF system power consumption and to ease stability requirements to RF controls in the matched operation, it was proposed operating some of CESR superconducting cavities in a passive mode. A proof-of-principle experiment was performed in February 2001 to check feasibility of this mode of operation [38]. The experiment was done at high beam energy (5.3 GeV) with one of four CESR cavities switched to passive mode. It was detuned far from resonance until beam current reached 100 mA. Then the tuner feedback loop was activated to keep the cavity voltage at 0.9 MV. It was possible to store beam current of 400 mA. The measured dependence of the synchrotron frequency on the beam current was in good agreement with calculations. More experiments followed at lower beam energy with the cavity external Q factor adjusted to 10^6 from the nominal value of 2×10^5 using waveguide transformer [25]. Trial HEP run showed that it is possible to reach luminosity comparable with that reached during normal operating conditions. However, energy kick due to beam interaction with this relatively low- Q resonance can produce rather large differential orbit perturbation between electrons and positrons and, as a result, can reduce the luminosity of the collider [39]. To avoid this undesirable effect, it is necessary to increase external Q even more, to 10^7 , which is possible with the insertion of a short in the waveguide in an appropriate place. Further studies of operation with passive cavities in CESR are under way and routine operation is expected to begin later this year.

Landau Cavity for BESSY-II

The Landau cavity module [40] is based on a one third scale model of the CESR B-cell cavity. Similarly to SLS and ELETTRA, this third harmonic cavity will run in the passive mode. The cavity has reached 7 MV/m during vertical cold test at DESY [41]. The cryostat for this cavity has been designed and is at present in the final stage of fabrication at ACCEL. Eventually the single superconducting cavity will replace four normal-conducting Landau cavities that are presently in operation at BESSY-II [42].

OTHER APPLICATIONS: CRAB CAVITY

Another “non-traditional” application of superconducting RF to high current colliders is a crab cavity system under development at KEK [43]. KEKB is operating with a crossing angle of 2×11 mrad. Beam-beam collisions occurring at an angle may induce a synchro-betatron resonance, which will in turn hurt luminosity. To avoid this resonance one can make the head-on collisions employing the crab-crossing scheme. There are four deflecting SRF cavities in the scheme. Two cavities kick bunches transversely before their collision to rotate them by 11 mrad, and two other cavities kick bunches after the collision to restore the initial orientation. The crab cavity [44] has a non-axisymmetric, squashed cell, coaxial input coupler, beam-line HOM absorber, and a special coaxial HOM coupler with the crab-mode rejection filter.

Two full-scale crab cavities were fabricated and tested, exceeding the design specifications. A conceptual design of the cryostat is completed, and detailed design is in progress. The crab cavities will be installed in KEKB in 2005.

SUMMARY

Two fundamental SRF systems currently in operation at high-current $\beta = 1$ accelerators are those at CESR and KEKB. Both systems achieved remarkable results in supporting ampere-scale average beam currents with high RF power (up to 380 kW per cavity) and accelerating voltage by strongly HOM-damped niobium cavities. Successful and reliable high beam current operation of these two systems encouraged other laboratories to consider superconducting RF as a good option for new RF systems. With the technology transfer to industry (ACCEL) and close inter-laboratory collaborations (Saclay/CERN/ESRF and Saclay/CERN/SLS/ELETTRA) the SRF technology has become the technology of choice for new projects at laboratories, which did not have prior SRF experience. Three third generation light sources (TLS, CLS, DIAMOND) had chosen CESR B-cell cryomodules for their RF systems. The first cryomodule for CLS was recently commissioned. Fabrication of other cryomodules is in progress at ACCEL. BEPC-II RF system will be based on the KEKB superconducting cavity cryomodule.

Two SRF systems under development for the French third generation light source SOLEIL and for the hadron collider LHC have some common features. They both utilize niobium-sputtered-on-copper technology developed at CERN for LEP. To absorb HOM power both cavities have loop coupler rather than beam-line ferrite absorbers used in CESR and KEKB cavities. The prototype two-cavity cryomodule for SOLEIL was successfully beam-tested at ESRF in 2002. Five four-cavity LHC cryomodules are assembled, tested at low power and ready to receive the last components: input power couplers.

Using passive superconducting cavities for bunch length manipulation is a new trend. First successful applications for bunch lengthening are third-harmonic cavities at ELETTRA and SLS. BESSY-II plans to replace four normal conducting third harmonic Landau cavities with a single superconducting cavity in near future. Experiments with beam-driven superconducting cavity in bunch-shortening mode were done at CESR-c. The crab cavity system development is in progress at KEK. More new projects are considering superconducting option for RF systems (NSLS-II, TESLA damping ring, PETRA-III...).

ACKNOWLEDGEMENTS

The author would like to acknowledge help of following colleagues, who provided updates on status and performance of their systems as well as some illustrations: T. Furuya (KEK), M. Svandrlík (Synchrotron TRIESTE), R. Losito (CERN), M. Pedrozzi (SLS), M. Dykes and M. Jensen (Daresbury), M. Pekeler (ACCEL).

REFERENCES

- [1] S. Belomestnykh and H. Padamsee, "Performance of the CESR Superconducting RF System and Future Plans," *Proceedings of the 10th Workshop on RF Superconductivity*, Tsukuba, Japan, 2001, pp.197-201.
- [2] K. Akai, et al., "RF systems for the KEK B-Factory," *Nuclear Instruments and Methods in Physics Research A* **499** (2003) 45-65.
- [3] D. Proch, et al., "Superconducting Cavities for HERA," XVth International Conference on High Energy Accelerators, Hamburg, Germany, 1992, in *Int. J. Mod. Phys. A (Proc. Suppl.)* **2B** (1993), Vol. II, pp. 688-690.
- [4] P. Brown, et al., "Operating Experience with the LEP2 Superconducting RF System," *Proceedings of the 10th Workshop on RF Superconductivity*, Tsukuba, Japan, 2001, pp. 185-193.
- [5] Y. Kojima, et al., "Upgrading of TRISTAN by Superconducting RF System," *Proceedings of the 1989 IEEE Particle Accelerator Conference*, Chicago, IL, 1989, Vol. 3, pp. 1789-1791.
- [6] H. Padamsee, "Review of Experience with HOM Damped Cavities," *Proceedings of the 6th European Particle Accelerator Conference*, Stockholm, Sweden, 1998, pp.184-188.
- [7] J. Kirchgessner, "The Use of Superconducting RF for High Current Applications," *Particle Accelerators*, 1994, Vol. **46**, pp. 151-162.
- [8] D. Boussard and T. Linnecar, "The LHC Superconducting RF System," *Proceedings of the 1999 Cryogenic Engineering Conference*, Montreal, Canada, published in *Advances in Cryogenic Engineering*, Vol. **45**, p. 385, 1999.
- [9] S. Li, et al., "The Feasibility Study on BEPC-II RF System," *Proceedings of the Second Asian Particle Accelerator Conference*, Beijing, China, 2001, pp. 687-689.
- [10] C. Thomas-Madec, et al., "Synchrotron SOLEIL Superconducting RF Status," this workshop.
- [11] G.H. Luo, et al., "The Taiwan Light Source and Superconducting Cavity," *Proceedings of the Second Asian Particle Accelerator Conference*, Beijing, China, 2001, pp. 495-499.
- [12] L. Dallin, et al., "The Canadian Light Source," *Proceedings of the 2003 Particle Accelerator Conference*, Portland, OR.
- [13] R. Bate, et al., "The Diamond Light Source RF System," this workshop.
- [14] P. Bosland, et al., "Third Harmonic Superconducting Passive Cavities in ELETTRA and SLS," this workshop.
- [15] M. Pedrozzi, et al., "SLS Operational Performance with Third Harmonic Superconducting System," this workshop.
- [16] M. Svandrlík, et al., "Performance of the 3rd Harmonic Superconducting Cavity at ELETTRA," this workshop.
- [17] S. Bauer, et al., "Industrial Production of Turn Key Superconducting Accelerator Modules for High Current Storage Rings," *Proceedings of the 2001 Particle Accelerator Conference*, Chicago, IL, 2001, pp. 1172-1174.
- [18] M. Svandrlík, et al., "The SUPER-3HC Project: An Idle Superconducting Harmonic Cavity for Bunch Length Manipulation," *Proceedings of the 7th European Particle Accelerator Conference*, Vienna, Austria, 2000, pp. 2052-2054.
- [19] J. Kirchgessner, et al., "Superconducting RF Activities at Cornell University," *Proceedings of the 7th Workshop on RF Superconductivity*, Gif-sur-Yvette, France, 1995, Vol 1., pp. 35-37.
- [20] H. Padamsee, et al., "Design Challenges for High Current Storage Rings," *Particle Accelerators*, 1992, Vol. **40**, pp. 17-41.
- [21] E. Chojnacki, et al., "Beam Line RF Load Development at Cornell," *Proceedings of the 1999 Particle Accelerator Conference*, New York, NY, Vol. 2, pp. 845-847.
- [22] H. Padamsee, et al., "Beam Test of a Superconducting Cavity for the CESR Luminosity Upgrade," *Proceedings of the 1995 Particle Accelerator Conference and International Conference on High-Energy Accelerators*, Dallas, TX, May 1995, Vol. 3, pp. 1515-1517.
- [23] D. Rubin, et al., "CESR Status and Performance," *Proceedings of the 2001 Particle Accelerator Conference*, Chicago, IL, June 2001, pp. 3520-3522.
- [24] D. Rice, "CESR-c – a Frontier Machine for QCD and Weak Decay Physics in the Charm Region," *Proceedings of the Eighth European Particle Accelerator Conference*, Paris, France, June 2002, pp. 428-430.

- [25] S. Belomestnykh, et al., "Using Passive Cavities for Bunch Shortening in CESR," *Proceedings of the 2003 Particle Accelerator Conference*, Portland, OR.
- [26] T. Tajima, et al., "Development of HOM Damper for B-Factory (KEKB) Superconducting Cavities," *Proceedings of the 1995 Particle Accelerator Conference and International Conference on High-Energy Accelerators*, Dallas, TX, May 1995, pp. 1620-1622.
- [27] S. Mitsunobu, et al., "High Power Input Coupler for KEKB SC Cavity and New 1 MW Test Bench," this workshop.
- [28] T. Furuya, et al., "Beam Test of a Superconducting Damped Cavity for KEKB," *Proceedings of the 1997 Particle Accelerator Conference*, Vancouver, Canada, May 1997, pp. 3087-3089.
- [29] T. Furuya, et al., "Achievements of the Superconducting Damped Cavities in KEKB Accelerator," this workshop.
- [30] A. Mosnier, et al., "General Layout of the SOLEIL SRF Unit," *Proceedings of the 8th Workshop on RF Superconductivity*, Abano Terme (Padova), Italy, 1997, Vol. 4., pp. 510-517.
- [31] S. Chel, et al., "Power Tests of the SOLEIL Cryomodule," *Proceedings of the 7th European Particle Accelerator Conference*, Vienna, Austria, 2000, pp. 2046-2048.
- [32] J. Jacob, et al., "Test of the SOLEIL Cryomodule Prototype with Beam at ESRF," this workshop.
- [33] R. Losito, et al., "Report on Superconducting RF Activities at CERN from 2001 to 2003," this workshop.
- [34] H. Vogel, et al., "Superconducting Accelerator Modules for the Taiwan Light Source," *Proceedings of the 7th European Particle Accelerator Conference*, Vienna, Austria, 2000, pp. 711-713.
- [35] M. Pekeler, et al., "Installation, Commissioning and Test Results of Superconducting RF Modules for Light Sources and Electron Storage Rings," this workshop.
- [36] J.M. Byrd and M. Georgsson, "Lifetime Increase Using Passive Harmonic Cavities in Synchrotron Light Sources," *Phys. Rev. ST Accel. Beams*, Vol. 4, 030701 (2001).
- [37] P. Bosland, et al., "SUPER-3HC Cryomodule: Layout and First Tests," *Proceedings of the 8th European Particle Accelerator Conference*, Paris, France, 2002, pp. 2217-2219.
- [38] S. Belomestnykh, et al., "Superconducting RF System Upgrade for Short Bunch Operation of CESR," *Proceedings of the 2001 Particle Accelerator Conference*, Chicago, IL, June 2001, pp. 1062-1064.
- [39] D. Rubin, private communication.
- [40] P. vom Stein, et al., "A Superconducting Landau Accelerating Module for BESSY II," *Proceedings of the 2001 Particle Accelerator Conference*, Chicago, IL, 2001, pp. 1175-1176.
- [41] S. Bauer, et al., "Fabrication, Testing and First Operation of Superconducting Accelerator Modules for Storage Rings," *Proceedings of the 2003 Particle Accelerator Conference*, Portland, OR.
- [42] M. Georgsson, et al., "First Experimental Results on Landau Cavities in BESSY II," *Proceedings of the 7th European Particle Accelerator Conference*, Vienna, Austria, 2000, pp. 1963-1965.
- [43] H. Nakai, et al., "Research and Development Program on Superconducting Crab Cavities for KEKB," this workshop.
- [44] K. Akai, et al., "Crab Cavity for the B-Factories," XVth International Conference on High Energy Accelerators, Hamburg, Germany, 1992, in *Int. J. Mod. Phys. A (Proc. Suppl.)* **2B** (1993), Vol. II, pp. 757-759.