

ON POWER SPLITTING FOR CORNELL ERL INJECTOR CAVITIES

V. Veshcherevich

In Cornell Energy Recovery Linac project (ERL) [1], each of the five injector cavities will be driven by a 1300 MHz 150 MW CW klystron through a twin input coupler [2]. The twin coupler consists of two identical antenna type couplers, and the magnitudes and phases of RF fields applied to each of these couplers must be very close to each other. This should be done by means of a power dividing system.

Requirements to the power dividing system are very strict. A difference of field magnitudes on individual coupler antennae should not exceed 1-2%, and a phase difference should not exceed 1° [2]. The only way to fulfill these requirements is to use tuning devices in waveguide system which may be adjustable power dividers and phase shifters. A similar system (with similar requirements) is used, for instance, in the RF system of JAERI/KEK high-intensity proton linac [3].

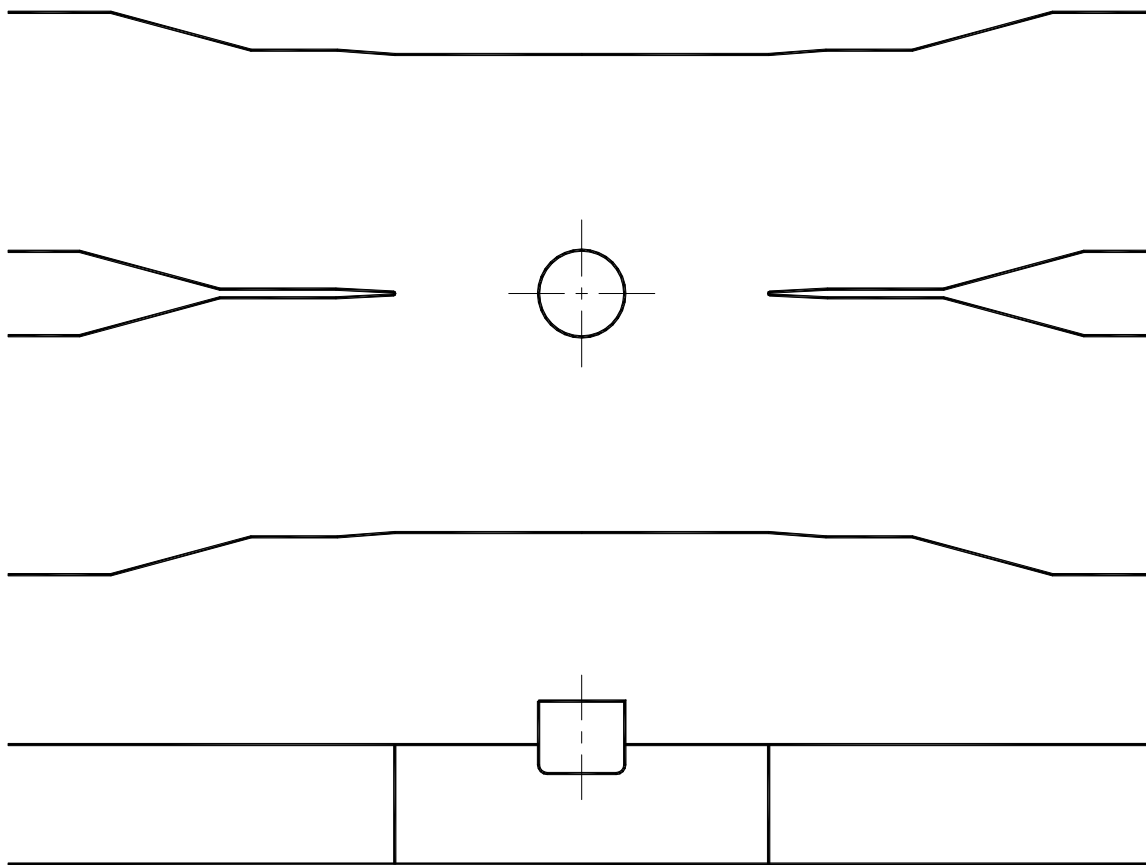

Figure 1: Schematic view of an adjustable short slot hybrid.

While different types of power dividers can be used here, power dividers using 3 dB short slot hybrids seem to have the best electrical properties: low sensitivity to mismatch, a wide frequency band, and the best high power handling [4].

For power balance, an adjustable stub in the middle point of the short slot hybrid can be used. Schematic view of this hybrid is shown in Figure 1. By varying its penetration into the waveguide, one can adjust the power ratio between hybrid output arms with a very small phase error. See, for example, a graph illustrating tuning of a 324 MHz short slot hybrid of JAERI/KEK high-intensity proton linac in Figure 2. Application of similar devices was considered for TESLA project [5].

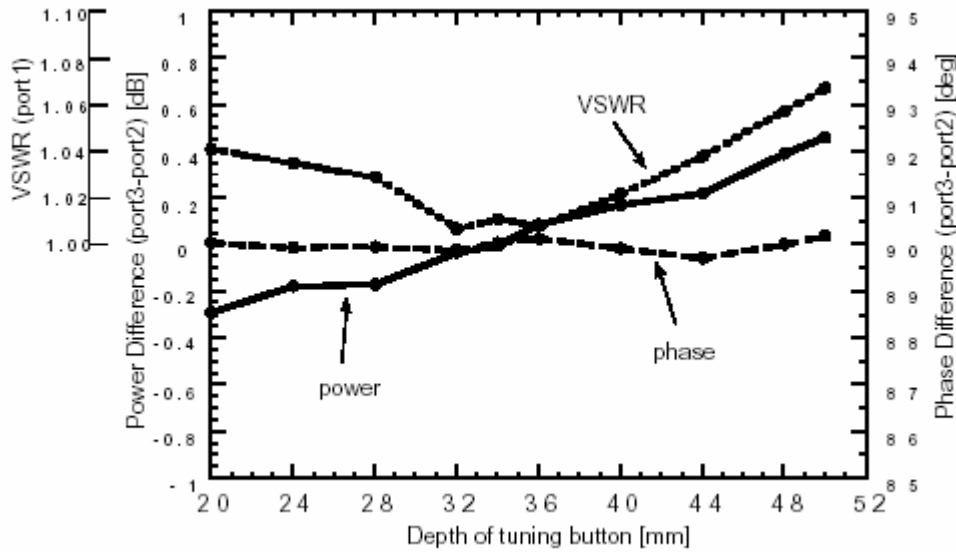

Figure 2: Tuning characteristics of the JAERI/KEK power divider.

As a phase tuner, a two-stub device can be used (Figure 3). Insertion of a stub into a waveguide produces capacitive admittance and an additional phase shift, these two values depending on the depth of the stub insertion. Figure 4 presents dependence of the stub admittance from the depth of the stub insertion, for the stub with a diameter of 10 mm in

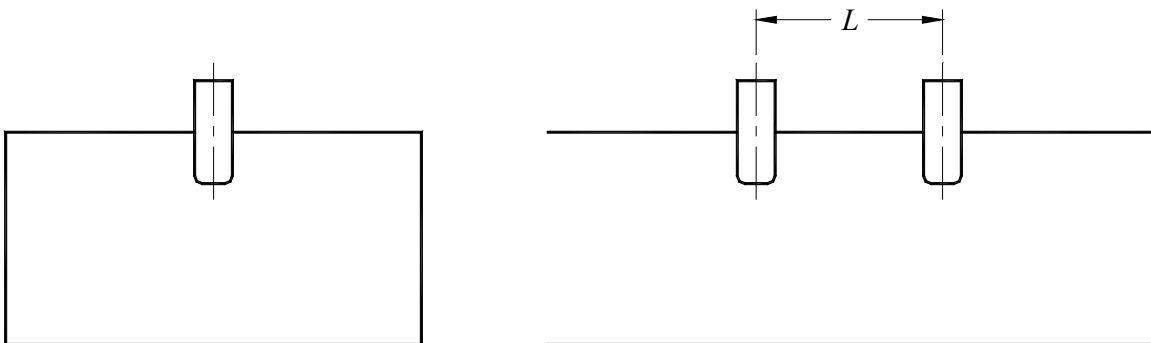

Figure 3: Schematic view of a two-stub phase tuner.

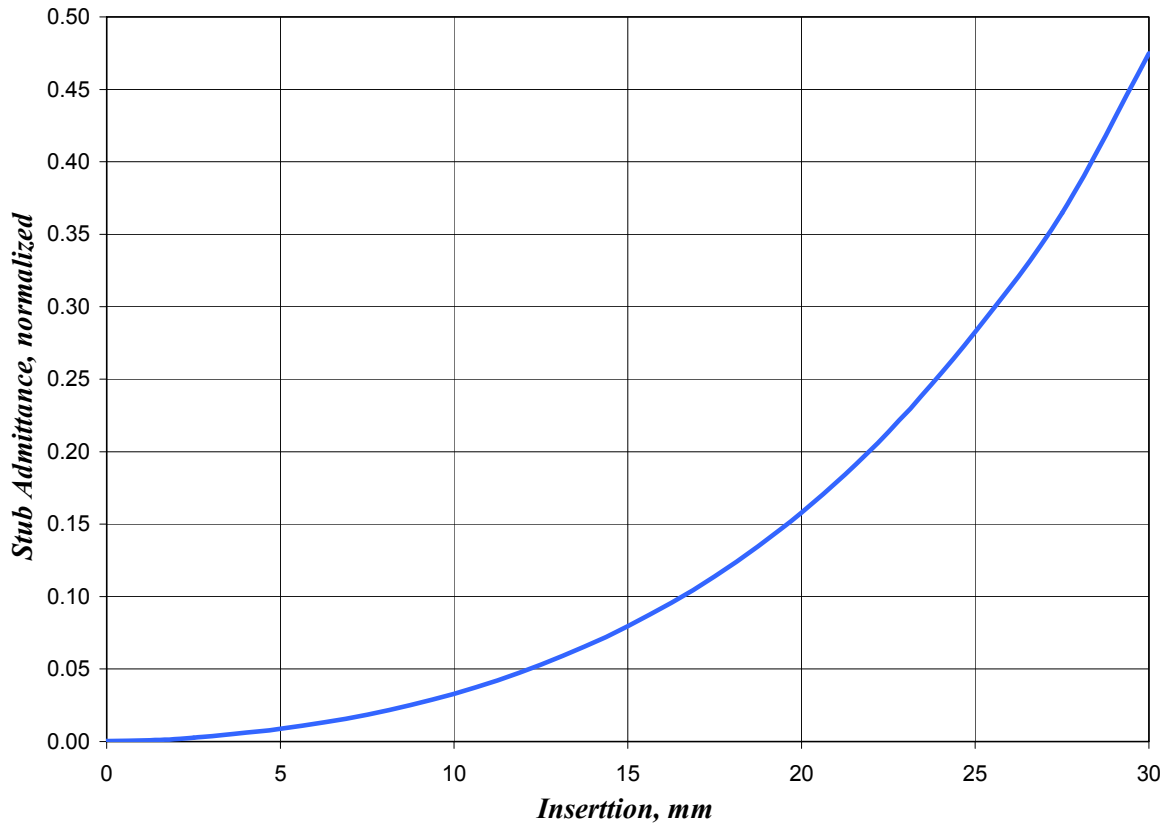

Figure 4: Normalized reactive admittance of a stub with a diameter of 10 mm.

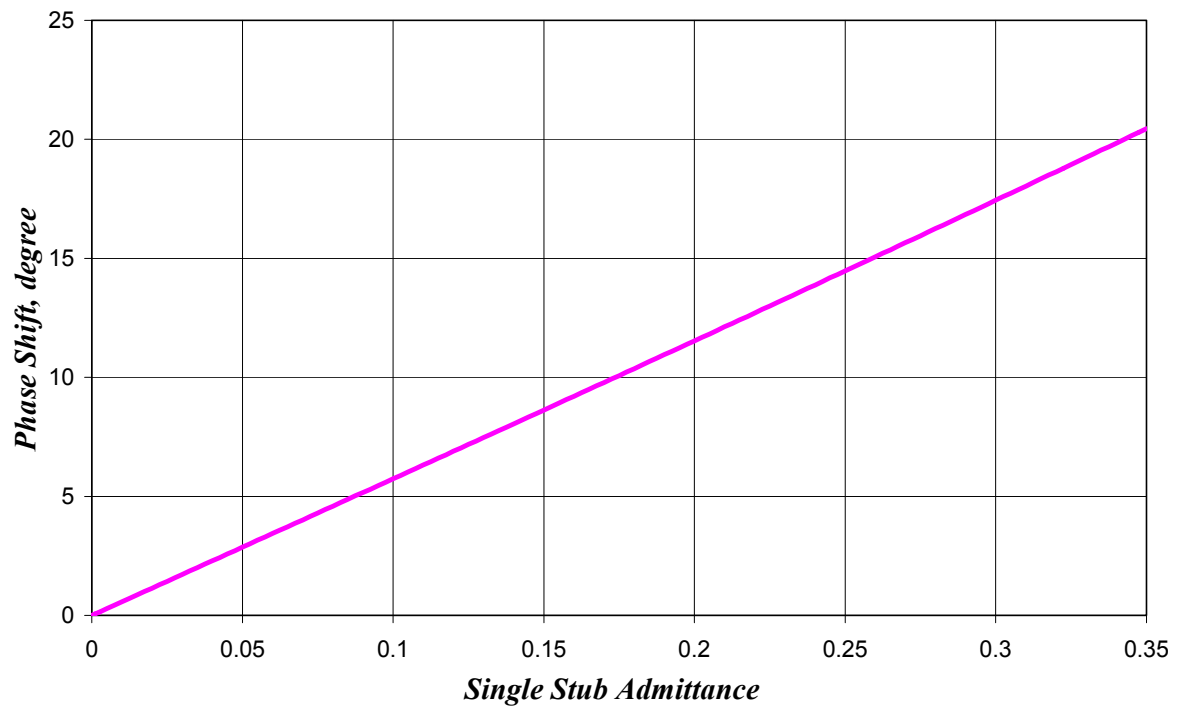

Figure 5: Phase shift of a two-stub phase tuner as a function of stub admittance.

a WR650 waveguide. This result was obtained by the 3D computer code CST Microwave Studio® [6]. The stubs should be positioned with an offset L of approximately a quarter of the guide wave length (80.55 mm) and move simultaneously. In this case, reflections from the stubs compensate each other whereas phases are always combined. Optimal offset value depends on the stub admittance: the higher the stub admittance is, the shorter should be the offset L (see Figure 6). The phase shift produced by a two-stub phase tuner linearly depends on stub reactance (see Figure 5). One can see that, with an offset $L = 73.4$ mm, we can vary the phase in a range of 20° keeping reflection below -40 dB.

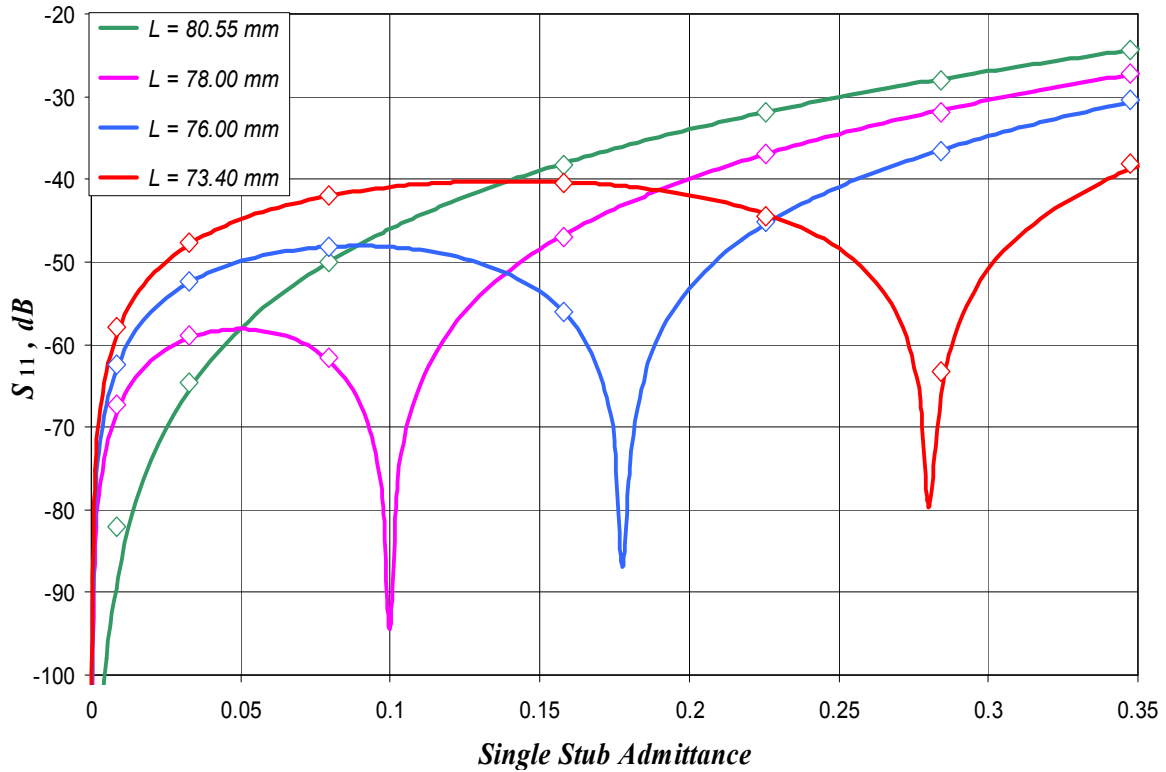

Figure 6: Reflection from a two-stub phase tuner as a function of the stub admittance for different distances L between the stubs. Solid lines represent analytical calculations for an ideal model, diamond dots represent calculations made by the computer code Microwave Studio.

A schematic 3D view of power distribution system for an ERL injector cavity with a 3 dB short slot hybrid divider is shown in Figure 7.

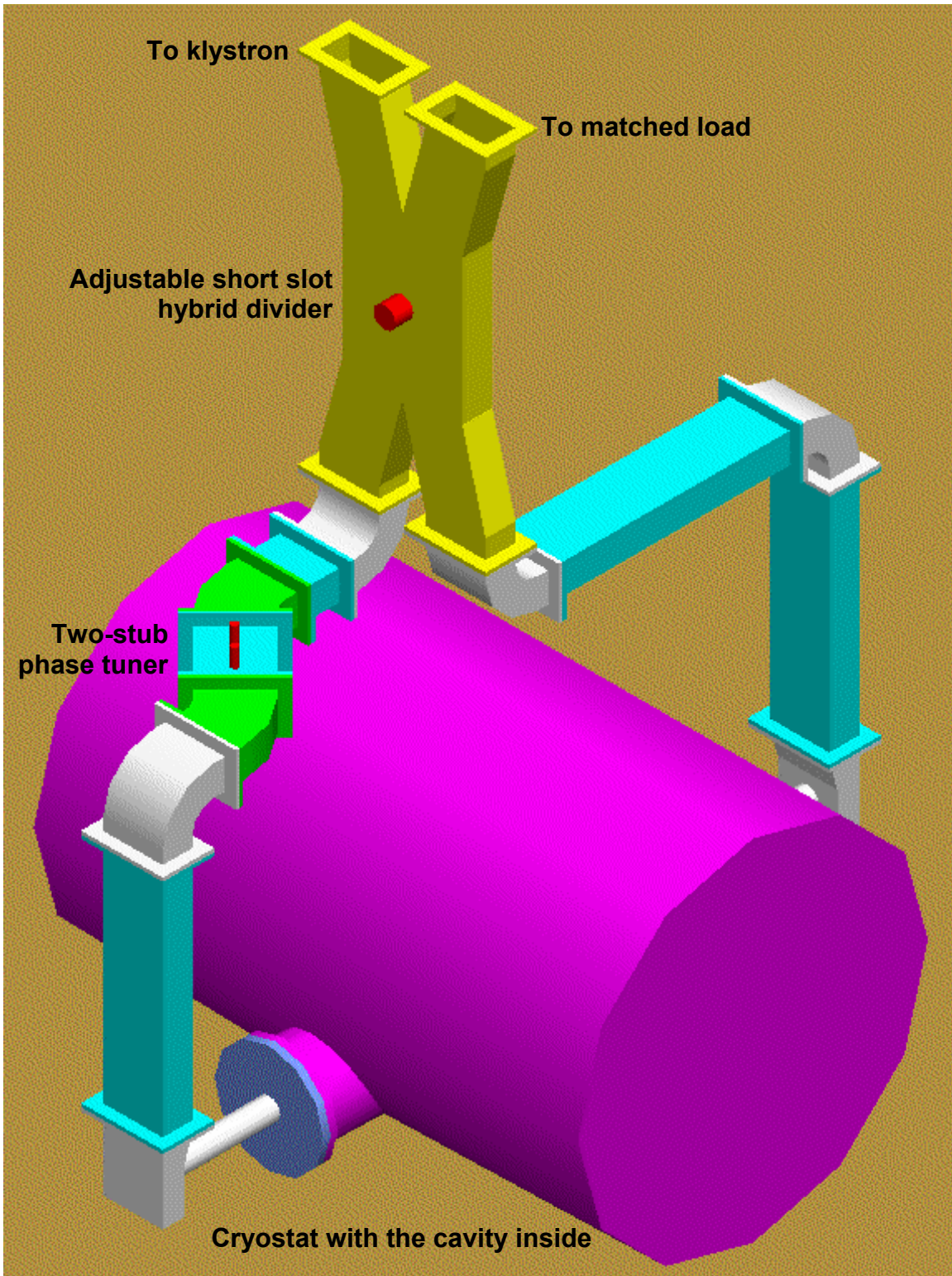

Figure 7: 3D view of power splitting scheme for an ERL injector cavity.

A FEW REMARKS ON RF MEASUREMENTS

The accuracy of final magnitude and phase balance depends not only on adjusting devices and tuning procedure, but also and mainly on measuring techniques and accuracy of measurements. We need to measure and adjust power and phase balance on output arms of the power divider. Also we need to measure phases of each coupler with the waveguide pieces attached to them. Only the measurements of straight waveguide parts can be omitted: the phases, corresponding to them, can be easily calculated. Flexible waveguide parts should not be used in waveguide assemblies between power divider and cavity couplers because they are sources of phase errors. We need to use only rigid waveguide pieces and shims (1 mm of the waveguide is equivalent to the phase of 0.9°). Measurements should be done using a well-calibrated network analyzer with cables being as short as possible (even the use of calibrated cables may lead to non-negligible phase errors due to their bending). The measurements of two individual cavity couplers should be made immediately one after another, using the same calibration.

REFERENCES

- [1] G. Hoffstaetter et al. "The Cornell ERL Prototype Project." In: Proc. of the 2003 Particle Accelerator Conf. (Portland, OR). Web page: http://warrior.lbl.gov:7778/pacfiles/papers/TUESDAY/AM_ORAL/TOAC005.PDF.
- [2] V. Veshcherevich et al. "Input Coupler for ERL Injector Cavities." In: Proc. of the 2003 Particle Accelerator Conf. (Portland, OR). Web page: http://warrior.lbl.gov:7778/pacfiles/papers/TUESDAY/AM_POSTER/TPAB009/TPAB009.PDF.
- [3] S. Yamaguchi et al. "Overview of the RF System for the JAERI/KEK High-Intensity Proton Linac." In: Proc. of the LINAC 2002 (Gyeongju, Korea), pp. 454-456.
- [4] V. I. Volman and Yu. V. Pimenov. "Electrodynamics for Engineers." Moscow, Russia, 1971.
- [5] B. Bogdanovich et al. "Design of an E-H Tuner and an Adjustable Directional Coupler for High-Power Waveguide Systems." In: Proc. of EPAC 2002 (Paris, France), pp. 506-508.
- [6] CST GmbH, Darmstadt, Germany.