

TO THE OPTICAL STOCHASTIC COOLING TEST AT CESR

E.Bessonov[†], M.Gorbunkov[†], A.Mikhailichenko^{††}

[†]Lebedev Phys. Inst. RAS, Moscow, Russia, ^{††}Cornell University, LEPP, Ithaca, NY 14853, U.S.A.

Abstract. We investigate here a possibility for test Optical Stochastic Cooling (OSC) method at CESR. Feasible application of OSC and its variants for muon cooling makes this method valuable for further implementation in muon collider.

1. OVERVIEW

Optical Stochastic Cooling (OSC) [1] is a new technology in stochastic cooling method. This method and its modifications [2], [3] uses optical amplifier with its wide absolute bandwidth value in a feedback loop. Appropriate undulator (helical or planar) used as a pickup and the other one as a kicker, closing the feedback loop (beam–undulator–optical amplifier–undulator–beam).

OSC method considered for muon cooling in [4], coming to conclusion, that moderate-size cooling system, ~ 100 m long, could deliver 2 ms damping time, what is \sim one muon decay time at 100 GeV-muon beam. Luminosity of muon collider with OSC system could reach 10^{35} cm⁻²s⁻¹ at 2 TeV beam energy with ~ 4400 times fewer muons per beam than in original proposal for muon collider. This drastically reduces intensity of the primary proton beam.

Ion cooling at LHC with OSC considered in [5]. It was shown, that for ⁸²Pb with typical parameters of LHC, a system with single pickup and single kicker undulator delivers damping time ~ 42 min with moderate amplifier having output power ~ 164 W. Cooling of ⁷⁹Au at RHIC considered in [6]. Here was shown, that optical amplifier with average power ~ 16 W could deliver cooling time ~ 1 hour. System emerges as absolutely feasible for usage in RHIC.

Cooling of beam halo becomes mostly straightforward application of OSC method here. Specifically, halo particle confinement in the VLHC considered in [7]. Here the grating with appropriate period used as a radiator and a kicker instead of undulator.

Proposal to test OSC in electron machines at Bates [8] and at Moscow [9] are only self consistent ones for the time being. Some possibilities for OSC test at dedicated damping ring considered in [10].

So the positive result with OSC test will open ways to many interesting applications worldwide. Definitely, it is not late, in case of success to install such system at FNAL.

2. EQUIPMENT

Simplest and controllable way to arrange delay of particle beam with respect to its radiation—is a chicane (see Fig. 1). As the distance between undulators is not big, it is easier to transfer the structure of fluctuations to second (kicker) undulator without phase degradation.

Enhanced Optical Cooling (EOC) – modification of OSC, [3] (see references there) helps in this as it deals with *fraction* of all radiated EM bucket by controllable way. Conditions for minimal distortion of sample could be easier satisfied if small fraction of the beam is under

operation at each moment only. As we mentioned, the mostly interesting application of this method might be in cooling down the halo of ion beam in LHC and muon cooling; this is exactly what EOC is promising to do.

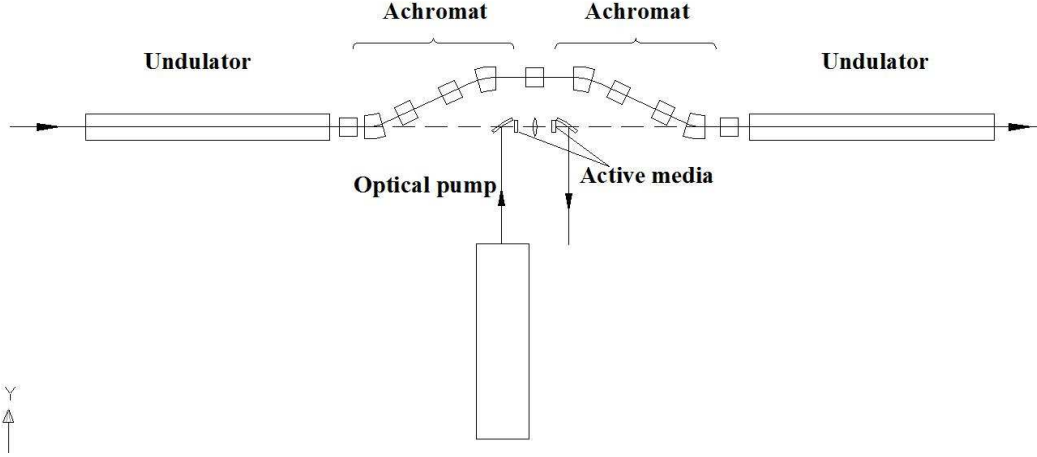

Figure 1: Basic setup. Optical amplifier shown has two stages. Optical pumping is going at ~doubled frequency of a signal.

The scheme shown in Fig.1 consists of two achromatic bends with appropriate electron-focusing elements. Basically there is requirement of isochronicity between the undulators' ends only. Each particle in the bunch should arrive to the entrance of second undulator simultaneously with the *front* of its amplified wavelet radiated in first undulator. So basically chicane compensates delay of wavelet in media of optical amplifier, focusing optics, optical isolator and transition windows (if any present on the optical pass). Achromatic condition is necessary but not sufficient for isochronicity as it could be seen from the following expression for the length difference between the path following strictly along central (reference) trajectory and the arbitrary one [11]

$$\Delta L = x_0 \int_{s_0}^{s_1} \frac{C(s, s_0) ds}{\rho(s)} + x'_0 \int_{s_0}^{s_1} \frac{S(s, s_0) ds}{\rho(s)} + \frac{\delta p}{p} \int_{s_0}^{s_1} \frac{D(s, s_0) ds}{\rho(s)}. \quad (1)$$

Here ρ stands for the local bending radius, $S(s)$ and $C(s)$ stand for Sin-like and Cos-like trajectories starting at the point of radiation s_0 and D stands for dispersion calculated from the same point

$$D(s_1, s_0) = -S(s_1, s_0) \cdot \int_{s_0}^{s_1} \frac{C(s, s_0)}{\rho(s)} ds - C(s_1, s_0) \cdot \int_{s_0}^{s_1} \frac{S(s, s_0)}{\rho(s)} ds. \quad (2)$$

Transverse position of particle has its usual form

$$x(s) = x_0 \cdot C(s, s_0) + x'_0 \cdot S(s, s_0) + D(s, s_0) \cdot (\delta p / p), \quad (3)$$

$$x(s) = x_{0\beta} \cdot C(s, s_0) + x'_{0\beta} \cdot S(s, s_0) + [\eta_0 \cdot C(s, s_0) + \eta'_0 \cdot S(s, s_0) + D(s, s_0)] \frac{\delta p}{p}, \quad (4)$$

where η stands for periodic solution of equation for dispersion so full displacement defined as $x = x_\beta + \eta \cdot (\delta p / p)$.

Pure achromatic transport system has $D(s_1)=0$, so

$$-S(s_1, s_0) \cdot \int_{s_0}^{s_1} \frac{C(s, s_0)}{\rho(s)} ds = C(s_1, s_0) \cdot \int_{s_0}^{s_1} \frac{S(s, s_0)}{\rho(s)} ds \quad (5)$$

For the purposes of OSC, the resulting energy dependent part of trajectory, at location of kicker undulator, must not be equal to zero, as the action to the particle is going through the energy change. Simultaneous cooling requires, that $\eta^{kick} + D^{kick} = -\eta^{pick}$, so $D^{kick} \cong -2 \cdot \eta^{pick}$, where by upper indexes mark the values of corresponding variable at location of kicker and pickup undulators respectively. So at least one among terms in (2) must not be a zero.

Different variants of OSC deal with different parts of this sum. EOC uses screening of fraction of radiation by controllable way, so only fraction of full image are going to optical amplifier.

Time delay in optical amplifier corresponds to the thickness of optical media which is equivalent of about 5-7 mm total of material having optical refraction coefficient $n \sim 2.1$ so the total delay comes to be $\delta \sim 10-15mm$ of equivalent beam pass delay. For the distance $L=1m \cong 1000mm$, for example, this requires offset Δx (see Fig.2) of the beam line in chicane as big as

$$\Delta x \cong \sqrt{L\delta} \cong \sqrt{1000 \cdot 15} \cong 122.5mm \sim 12.3 cm,$$

i.e. moderate one (two wings are working for delay). For shorter L this offset becomes smaller also, but the field value in a magnet increases also. Magnetic rigidity of 300-MeV beam is $(HR) = pc/300 = 10^3 kG \times cm$. So the bend to the angle $\Delta x' \cong \Delta x / L$ could be delivered by the field H_m defined from the following expression

$$\Delta x' = \frac{l}{\rho} \cong \frac{\Delta x}{L} \cong \frac{H_m \cdot l}{(HR)}, \quad (6)$$

Where l is the length of the magnet, ρ its bending radius so the bending angle $\varphi = l / \rho$, so

$$H_m \cong \frac{\Delta x}{L} \frac{(HR)}{l} \quad (7)$$

Substitute here for estimation $l=30cm$, one can obtain $H_m \cong 5kG$ with corresponding bending angle $\varphi \cong l / \rho \cong \Delta x / L \cong 0.15 rad \sim 9$ degrees. Quadrupoles between magnets must have

the focal distance $F \sim L/2$. As the focal distance defined as $F \cong \frac{1}{kl_Q} = \frac{(HR)}{Gl_Q}$, where G stands

for the gradient, and l_Q stands for the length of the lens, then gradient must be around

$$G \cong \frac{2(HR)}{Ll_Q}. \quad (8)$$

Substitute here for estimation $l_Q \approx 20cm$, gradient comes to be $G \cong 1kG/cm$. This number gives an idea of the quadrupole strength.

From the other hand the field increase could raise radiation from the magnet, which might work as a background noise.

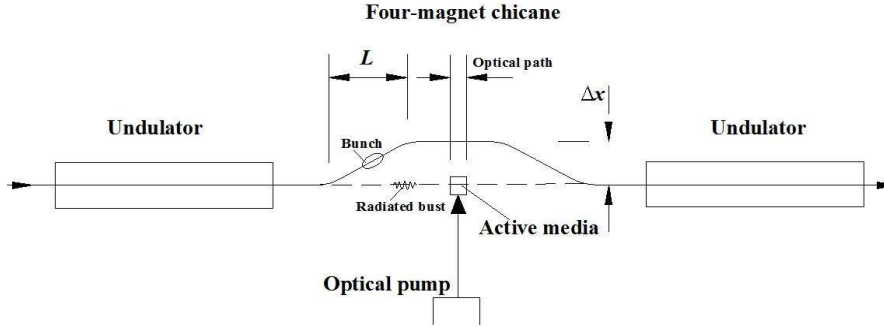

Figure 2: To determination of the offset value. Shorter the base L is—less offset required.

For the scheme when all equipment located in L0 (South Area in Fig.3), two wigglers installed closer to the center, need to be removed (see Section 3 below).

For easy switch between SR operation and OSC experiment we suggest to install two magnets, lenses and optical amplifier at movable platform, so it could be moved in vertical direction. The technique for exchange the lines without interruption of vacuum is well known (used in E-166 for example).

3. LOCATION AND COMPONENTS

There are two places at CESR suitable for this experiment. One located at the North area, at L3, the other one at the South, at L0 see Figure 3. In last variant some equipment could be shared with CESR-TA experiment, see Figure 4.

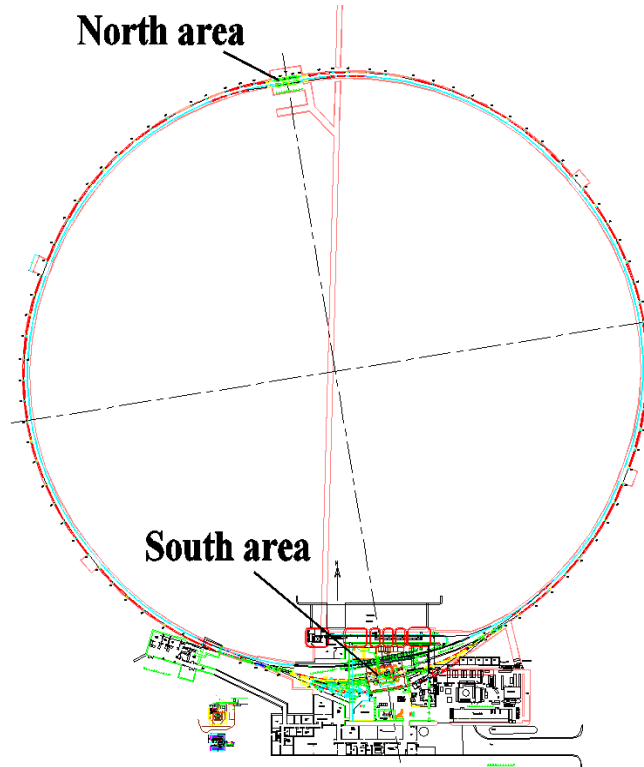

Figure 3: Possible locations for equipment at CESR. Location at the North area is preferable.

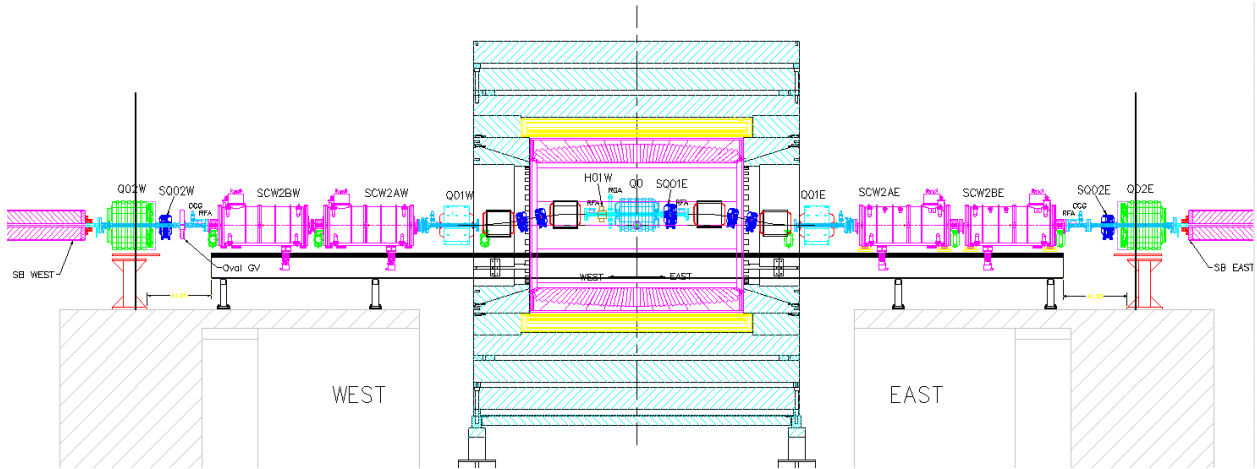

Figure 4: Beam chicane setup in L0, South Area. Detector CLEO yoke resides at the same place. This setup uses SC wigglers fabricated for CESR-C operation and used in CESR-TA program. Two central wigglers removed. If new made undulators used, they could be installed instead of these two shown here (at each side).

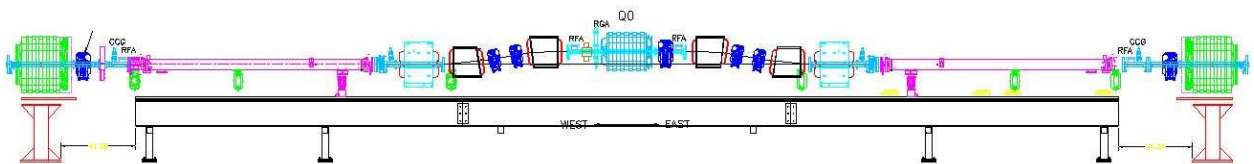

Figure 5: Beam chicane setup at North area with new-made undulators. The same setup could be used in L0, South Area; previous Figure.

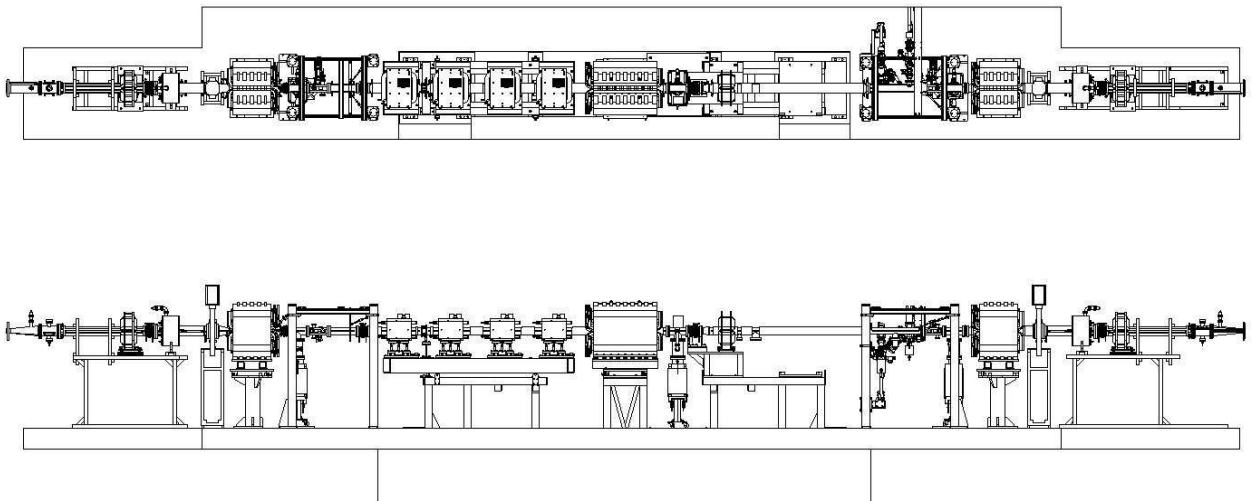

Figure 6: Existing chicane setup at North area used for CESR-TA experiments [16].

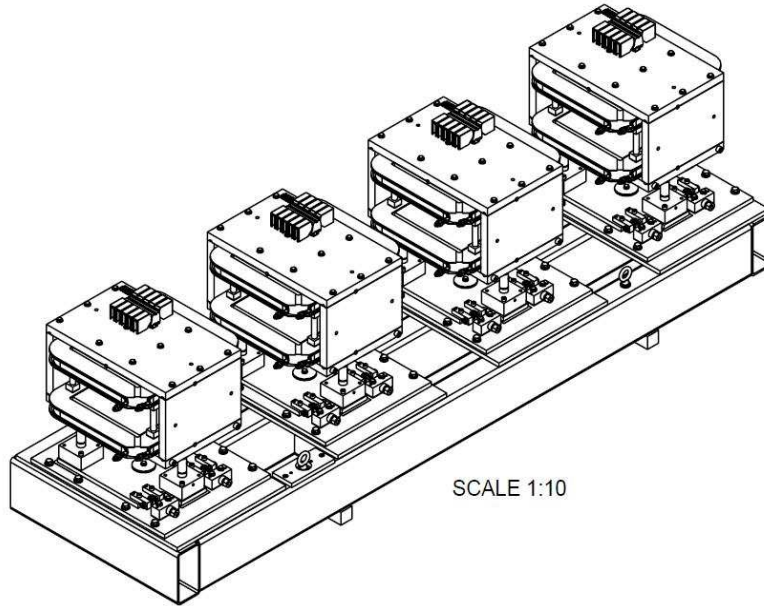

Figure 7: 3D view of existing chicane [16].

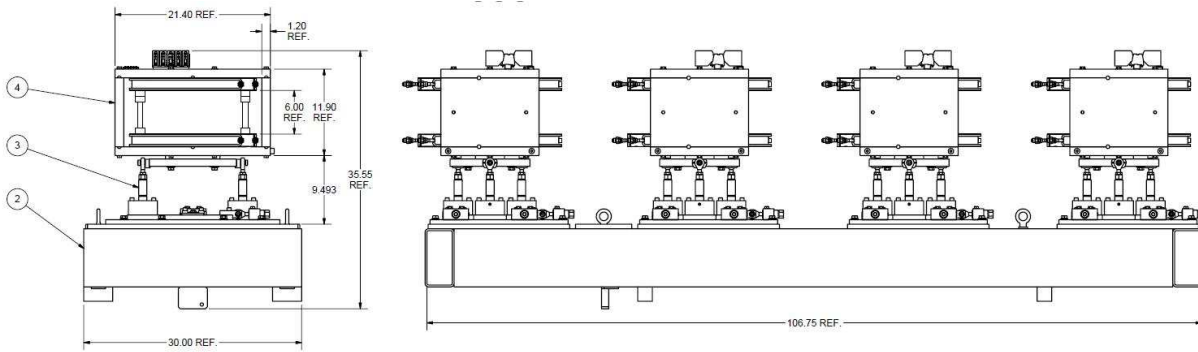

Figure 8: Dimensions of existing chicane.

One can see that modification of chicane hardware could be minimal.

4. OPTICAL AMPLIFIER

Few possibilities are open for the test: Optical Parametric Amplifier (OPA), Titanium Sapphire and Dye amplifier with Rh6J. OPA is mostly adequate here as it gives highest amplification.

OPA uses Crystal of MgO: PPLN (Periodically Polled Lithium Niobate) with a poling period of $\sim 31.1 \mu\text{m}$. This crystal could be located in a vacuum. This will exclude an optical delay and phase distortion introduced by windows. This MgO: PPLN crystal has high damage threshold and high nonlinear coefficient 16 pm/V . Crystal will be located on the base having temperature stabilization.

Effective thickness of two-stage amplifier active media is $\sim 2 \times 3.5 \text{ mm}$ (each, maximum), (see Fig.1). Taking into account the refraction index value $n \approx 2.1$, the optical delay comes to $\sim 14 \text{ mm}$; optical lenses and some trimming elements are working against, so the effective

difference in path lengths of optical signal and the bunch trajectory estimated to be $\sim 15\text{-}20$ mm. Once again, this requires offset $\Delta x \cong 12.5$ cm which is small, Fig.3. In reality the offset is planned to be up to ~ 15 cm.

Operation near the degeneracy wavelength of signal $2.128 \mu\text{m}$ reduces thermal-lens effect because the signal and the idler wavelengths fall within the highest transparency range of Lithium Niobate [5]. Pumping of active media is going at $\sim 1.06 \mu\text{m}$. Optical pumping is not a problem here: Yb doped fiber laser (+amplifier) could be used here. Total amplification of two stage amplifier achievable is 10^7 [5]. **Near-ultraviolet OPA** based on Beta-Barium Borate (BBO or $\beta\text{-BaB}_2\text{O}_4$) [13].

Usage of OPAs with shorter than considered above wavelength, will permit to increase the spatial resolution by the optical system and the rate of cooling of the beam. Transmission region is $0.19\text{-}3.5 \mu\text{m}$; damage threshold ~ 10 GW/cm² for 100 ps pulse width at $1.604 \mu\text{m}$. BBO is relatively soft and therefore requires precautions to protect its polished surfaces. Refractive index is increasing $\sim 10\%$ while the wavelength changing from $1.06 \mu\text{m}$ to $0.266 \mu\text{m}$, where is $n_o \approx 1.75$, $n_e \approx 1.61$. This crystal is mildly hygroscopic.

Operation in bandwidth within 400-800 nm allows increase of energy of electron beam accordingly, see formula (9) below.

BBO, is one of the best candidates for near-ultraviolet OPA pumped by fourth harmonic of a Nd or Yb lasers. Preliminary cost estimation for Optical Amplifier represented in Table 1.

Table 1: Cost of Optical Amplifier system for two wavelengths

Item	Cost, k\$ 2000nm	Cost, k\$ 400nm
Fiber laser	25	25
Optical isolators	3	3
MHz pulse picker	25	25
Grating stretcher	5	5
Two fiber based amplifiers, each providing 20 - 30 dB of gain	40	40
Fiber/bulk optic amplifier (>100W)	60	-
Solid state amplifier (>300W)	-	80
Grating Compressor	20/50	20/50
OPA MgO:PPLN crystals	20	20
OPA $\beta\text{-BaB}_2\text{O}_4$	3	3
2ω and 4ω $\beta\text{-BaB}_2\text{O}_4$	-	3
IR spectrometer	25	25
Optics (mirrors, lenses, delay)	20\70	20\70
Opto-Mechanical Components	20	20
Sub-picosecond synchronization electronics	20	20
Autocorrelator	15	15
Total	301 \ 381	324 \ 404
Streak camera	200	200

5. UNDULATORS

The path difference arranged with the help of four magnets, and set of quadrupoles, Fig. 1. Basically this is a mirror-symmetrical optics with respect to the middle point. Each half arranged with two magnets and two quads in first order; this scheme which is widely in use now was originated in [12].

Controllable dispersion changing in wigglers required delivered with some Panofsky-Hand type lenses, which could be added with minimal space required.

Energy of experiment $\sim 200\text{-}300$ MeV defined by optical amplifier central operational frequency which must coincide with first harmonics of undulator radiation.

$$\lambda_{\text{amplifier}} \cong \frac{\lambda_u}{2\gamma^2} \cdot (1 + \frac{1}{2} K^2), \quad (9)$$

so

$$\gamma \cong \sqrt{\frac{\lambda_u}{2\lambda_{\text{amplifier}}} \cdot (1 + \frac{1}{2} K^2)} \quad (10)$$

For $\lambda_{\text{amplifier}} \cong 2\mu\text{m}$, $\lambda_u \cong 40$ cm, $K=1$. $\gamma \cong \sqrt{\frac{3 \cdot 40}{4 \cdot 10^{-4}}} \cong 547$ i.e. $E \sim 280$ MeV. Some tuning is

possible by changing K factor. As $K \cong 93.4 \cdot B[T] \cdot \lambda_u[m]$, then magnetic field required for $K \sim 1$ comes to $B[T] \cong 0.027$ Tesla i.e. ~ 75 times smaller, than operational field at CESR-C wiggler. Taking into account absence of saturation which delivers factor ~ 2 , the current required comes to $\sim 160/75/2 = 1.1$ A only. Naturally, the wiggler can work without any cooling at all (maybe just water cooling or Nitrogen cooling of jacket). Anyway this is significant simplification.

Fabrication of undulator from the scratch is also a possibility as the field in undulator is small and the cost of such fabrication is low.

Helical undulator possible as well; in this case in formula (9) the factor $\frac{1}{2}$ needs to be

omitted, increasing $\gamma \rightarrow \gamma \sqrt{\frac{1+K^2}{1+\frac{1}{2}K^2}} \cong \gamma \frac{2}{\sqrt{3}} \cong 1.15\gamma$.

Lower energy makes damping slower, but from the other hand it makes identification of cooling process much easier, as expected damping rates for OSC are in millisecond range. Operation with higher K factor allows increase of energy. Presence of higher harmonics is not affecting experiment as these are out of bandwidth of amplifier.

6. SCOPE OF EXPERIMENT

Experiment is going at energy ~ 280 MeV. We are suggesting a quasi-pulsed operation, when accumulation of the beam is going at relatively high energy $\sim 1.5\text{GeV}$, where accumulation is tuned for CEST-C (Charmed) program and vacuum pumping is good also. Then the beam decelerated down to ~ 280 MeV and hold there relatively short time required by cooling experiment, then the process is repeated. Two CESR wigglers could be used, feed at low current (without Helium at all), two others need to be removed, if south area is in use. Beam optics needs to be tuned so that in kicker undulator the betatron phase reversed it sign with respect to dispersion function compared with pickup undulator. This may generate some non-isochronicity, see Section 2, but for EOC this could be tolerated.

As an option it might be desirable to feed the wigglers in a quadrupole mode, when polarity in upper (or lower half) switched to the opposite one. Commutation could be done without disassembling the upper half as the electrical communication done after upper and lower halves assembled together.

Registration of damping effect is an easy procedure. Beam size monitor must operate in infrared range. Damping time

$$\tau_x \cong 2\tau_s \cong \tau_y \cong \frac{2E}{\langle P_\gamma \rangle} = \frac{3mc^2}{r_0^2 \gamma \langle H_\perp^2 \rangle} \cong \frac{3}{r_0 \gamma^3 c \left\langle \frac{1}{\rho^2} \right\rangle} \quad (11)$$

where $H_\perp(s)$ is magnetic field value along longitudinal coordinate s , ρ is a current bending radius, $P_\gamma(s) = \frac{2}{3} r_0^2 \gamma^2 c H_\perp^2(s) = \frac{2}{3} e^2 \gamma^4 c / \rho^2$ is power of radiation. At energy 280 MeV it will be ~1000 times bigger, than for 2.8 GeV, coming to a hundred second level. So that is why accumulation and preliminary cooling could be carried at higher energy, say energy of experiment at 2 GeV, then the beam decelerated ~ten times. As emittance will grow adiabatically in the same proportion as the energy does, it will be enough room for the beam at lower energy.

Experiment begins with registration interference of radiation from two undulators. Optical amplifier is in "off" regime.

For reduction of damping time the other wigglers (up to twelve, if new fabricated undulators used as pickup and kicker) could work at full current. At least six other wigglers could remain at their places unmoved. If undulators installed at North area, all twelve SC wigglers could work for damping, remaining at their places established by CESR-TA experiment.

Vacuum pumping becomes more complicated as the field is low and ion pumps are not working well, but quasi-pulsed mode of operation might be OK for vacuum. Some additional pumps could be required.

PS operation; probably ballast resistor will be required for normal operation of current-stabilization-feedback. Lenses are driven by individual power suppliers; there will be no problems in operation at low current

Bunch population suitable for experiment lies in 10^4 - 10^{10} per bunch.

Toushek effect could be made small by keeping length of bunch as long as possible.

7. SCHEDULE AND RESOURCES

Few beam studies runs required for identification of possible narrow places to run CESR at low energy.

Using existing elements of bypass (four magnets) and manufacturing optical amplifier in advance, could reduce down period.

Once again, new set of room temperature undulators, made from scratch looks as inexpensive enterprise. This undulator can be made as a *helical* one, so the cost of fabrication of 40cm-period room temperature undulators becomes very low. In that case the length of undulators could be extended to ~3 meters; two other wigglers at each side (four in total) will be removed from central region to the other place.

Collaboration with Moscow FIAN, MIT Bates, BNL, Berkeley Lab and FERMILAB is a widely open; this will enhance position of LEPP among other accelerator Labs.

8. EXAMPLE WITH MUON COOLING

In muon collider scheme, which is accepted by accelerator community in general [14], we are suggesting some additional ring, which could be inserted right after the ring coolers shown in Figure 6.

So this is a ring with few, say 12 cooling systems of the type we are planning to test at CESR. So these 12 insertions (each having two SC wigglers and chicane plus lenses and own optical amplifier), using beta-Barium Borate amplifier. Between these sections there are optical elements for matching the necessary optical functions. For estimations we can use some parameters from paper [2], such as energy, $<100\text{GeV}$.

Just using bandwidth of BBO amplifier, reasonable length of bunch, number of particles we can estimate the damping time and emittance decrease.

One peculiarity with cooling muons is that the energy radiated by particle in an undulator, calculated with classic formulas, is not enough for build up the quanta, i.e. energy which radiated is less, than the energy of quanta. So some reduction in cooling rate occurs due to the circumstance, that the kick by kicker undulator is proportional to the square of quantum energy. So linear relation in reduction of number of quantas and theirs radiation rate becomes broken. Nevertheless, parameters remain attractive.

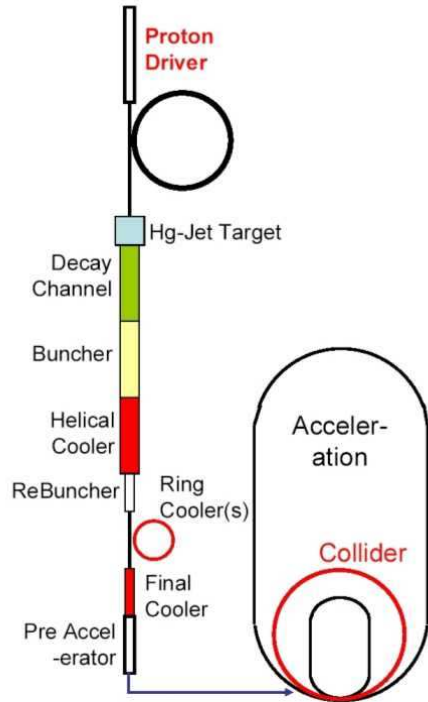

Figure 6: Muon Collider schematic for the design developed by the NFMCC [14].

In this section we represent estimations from [9], [15]. Parameters of the muon storage ring, undulators, optical system are represented in the Tables 2-4.

Table 2. Parameters of the ring for muon cooling.

Parameter	Value
Muon energy	$\epsilon_{\mu} \cong 1.836 \text{ TeV} (\gamma_{\mu} = 17.4 \cdot 10^3)$
Period of revolution	$T = 15 \mu s$
Muon decay time	$\tau_{\mu} = 38.1 \text{ ms}$
Muon beam damping time	$\tau_{\epsilon, x} = 38.1 \text{ ms}$
Limiting degree of cooling	$k_{\epsilon, x} = 11$
Beta function at pickup undulator	$\beta_{x, p} = 50 \text{ m}$
Beta function at kicker undulator	$\beta_{x, k} = 5 \text{ m}$
Dispersion functions at pickup undulator	$\eta_{x, p} = 10^3 \text{ m}$
Dispersion function at kicker undulator	$\eta_{x, k} = 30 \text{ m}$
Number of muons per a bunch	$N_{\mu} = 10^7$
Number of bunches	$N_b = 10^2$
Length of the muon bunch	$l_b = 2 \text{ m}$
Equilibrium beam energy spread	$\sigma_{\epsilon, eq} = 1.84 \cdot 10^6 \text{ eV} (\sigma_{\epsilon, eq} / \epsilon = 10^{-6})$
Initial energy spread	$\sigma_{\epsilon, 0} / \epsilon = 10^{-5}$
Equilibrium beam size at kicker undulator	$\sigma_{x, y, k eq} = 0.3 \text{ mm}$
Initial beam size at the pickup undulator	$\sigma_{x, y, p, 0} = 10 \text{ mm},$
Total beam size at the pickup undulator	$\sigma_{\Sigma, p, 0} = 14 \text{ mm}$

Table 3. Parameters of the optical system.

Parameter	Value
Wavelength of the OPA	$\lambda_{1, \min} = 4 \cdot 10^{-5} \text{ cm},$
Photon energy	$\hbar \omega_{1, \max} = 3.1 \text{ eV}$
Gain of OPA	$\alpha_{ampl} = 5.13 \cdot 10^{10}$
Waist size of the URW at kicker undulator	$\sigma_w = 1 \text{ mm}$
Number of noise photons	$N_n = 1$
Characteristic waist size	$\sigma_{w, c} = 0.378 \text{ mm}$
Transverse resolution	$\delta x_{res} \cong 2 \text{ mm}$
Power of URW beam	$P_{ampl}^{URW} = 1.76 \text{ kW}$
Noise power	$P_{ampl}^n = 3.82 \text{ W}$
Average power of amplifier	$P_{ampl} = 5.58 \text{ kW}$

Table 4. Parameters of helical undulators.

Parameter	Value
Undulator period	$\lambda_u = 1 \text{ m}$
Number of the undulator periods	$M=10$
Number of undulators	$N_p = N_k = 10$
Deflection parameter of undulators	$K = 22$
Undulator magnetic field strength	$\sqrt{B^2} = 48.7 \text{ T}$

In the EOC scheme unlike OSC one the non-exponential cooling regime is realized when the beam dimensions are decreased much more than $e=2.7$ times for one damping time.

9. SUMMARY

Cost of experiment to test OSC at CESR in first place determined by operational expenses. Funding must allow keeping CESR stuff busy for ~ 2 years. During this period normal SR runs are going on shift basis. Second in the cost line- is the Optical Parametric Amplifier.

Fabrication of chicane magnets (more likely could be used the ones after CESR-TA test experiment finished) and the movable frame is the third in cost line.

Cost of new-made helical undulators is low. In case of usage these new made undulators instead of wigglers, it is preferable to install these undulators at the North of CESR at L3, keeping optics and hardware at L0 untouched. For optical amplifier, the collaboration with other institutions could help in reduction of cost.

Table 5 summarizes parameters of experiment

Table 5: Main parameters of experiment

Item	value
Energy of experiment	250-350 MeV
Number of particles	10^4 - 10^8
Amplifier	OPA
Operational wavelength	$\sim 2\mu\text{m}$
Pumping wavelength	$\sim 1\mu\text{m}$
Power of amplifier	1-10W
Amplification	$<10^8$
Natural damping time	100s
OSC damping	10-50ms
Period of Undulator	40cm
Number of periods	5-10
K -factor	0.5-1.5
Type of undulator	Planar or helical

Some parameters represented in this table have wide margins, what is defined by some uncertainties at the moment. These margins will become narrower, while parameters of experiment and available resources become more determined. This experiment might be wide open for collaboration.

10. REFERENCES

- [1] A.Mikhailichenko, M. Zolotorev, "Optical Stochastic Cooling", *Phys .Rev. Letters* 71, 4146, (1993).
- [2] M.Zolotorev, A.Zholents, "Transit-Time Method of Optical Stochastic Cooling", *Phys. Rev. E* 50, 3087 (1994).
- [3] E.G.Bessonov, A.A.Mikhailichenko, "Enhanced Optical Cooling of Particle Beams in Storage Rings", published in Proc. 2005 Particle Accelerator Conference, May 16-20, 2005, Knoxville, Tennessee, USA, <http://www.sns.gov/PAC05>, <http://accelconf.web.cern.ch/accelconf/p05/PAPERS/TPAT086.PDF>.
- [4] W.Wan, A.Zholents, M.Zolotorev, "Optical Stochastic Cooling of Muons", PRST, Vol 4, 031001, (2001). <http://prst-ab.aps.org/pdf/PRSTAB/v4/i3/e031001>
- [5] E.G.Bessonov, M.V.Gorbunkov A.A.Mikhailichenko, "Enhanced Optical Cooling of Ion Beams for LHC". Particle Accelerator Conference (EPAC 06), Edinburgh, Scotland, 26-30 Jun 2006, Published in Edinburgh 2006, EPAC 1483-1485. http://arxiv.org/PS_cache/physics/pdf/0604/0604045v1.pdf <http://accelconf.web.cern.ch/accelconf/e06/PAPERS/TUPLS001.PDF> ;
Electronic Journal of Instrumentation – 2006 JINST 1 P08005, <http://jinst.sissa.it/>, http://ej.iop.org/links/r5pyfrsWE/sl44atI92xGGY2iAav5vpA/jinst6_08_p08005.pdf .
- [6] M.Barbizien, I.Ben-Zvi, I.V.Pavlishin, I.V.Pogorelsky, V.E.Yakimenko, A.Zholents, M.Zolotorev, PRST, Vol 7, 012801, (2004).
- [7] A. Zholents, W.Barletta, S. Chattopadhyay, M. Zolotorev, "Halo Particle Confinement in the VLHC using Optical Stochastic Cooling", Particle Accelerator Conference (EPAC 2000), Vienna, Austria, 26-30 Jun 2000. Published in Vienna 2000, EPAC 00* 262-264 <http://accelconf.web.cern.ch/AccelConf/e00/PAPERS/TUOAF102.pdf>
- [8] W.A. Franklin, "Optical Stochastic Cooling Proof-of-Principle Experiment", Proceedings of PAC07, Albuquerque, New Mexico, USA, WEOAKI01, pp.1904-1906. Proposal at BATES.
- [9] E.G.Bessonov, M.V.Gorbunkov A.A.Mikhailichenko, "Proposal for an Enhanced Optical Cooling System Test in an Electron Storage Ring," Published in Phys.Rev.ST Accel.Beams 11:011302, 2008, <http://arxiv.org/ftp/arxiv/papers/0704/0704.0870.pdf>
- [10] A.Mikhailichenko, "Damping ring to test OSC", CBN-06-06, 2006, <http://www.lns.cornell.edu/public/CBN/2006/CBN06-6/CBN06-6.pdf>
- [11] K. Steffen," *High Energy Beam Optics*", Interscience Pub., 1965.
- [12] V.V. Vladimirsky, D.G. Koshkarev, "The Achromatic Bending Magnet System", Instr. Exp. Tech., (USSR), (English Translation) N6, 770(1958).
- [13] Beta-Barium Borate, Fujian Institute of Research on the Structure of Matter (FIRSM), Chinese Academy of Science, see http://www.doehrer.com/download_e/pdf/F-BBO.pdf
- [14] NFMCC Web site: http://www.cap.bnl.gov/mumu/mu_home_page.html
- [15] E.G.Bessonov, M.V.Gorbunkov, A.A.Mikhailichenko, "Enhanced Optical Cooling of Muon Beams", JINST_008_0709, Jan 19, 2010; <http://www.iop.org/EJ/abstract/1748-0221/5/01/P01011> .
- [16] Y.Li, X.Liu, V.Medjidzade, M.A. Palmer, D.H.Rice, D.L.Rubin, J.J.Savino,"CESR-TA Vacuum System Modification", PAC09, paper ID: MO6RFP005, May 4-8, Vancouver, Canada, 2009.