

Capacitive-Antennae HOM Dampers

Harald Hahn

L. Hammons, E. Johnson, Wencan Xu
C-A Department, BNL

Outline

BNL ECX experience with ferrite damper

Summary results at **4 and 2 K**, power loss estimates

Cu cavities with Capacitive probe damper

Single cavity and cavity chain results

Probe Characterization in coax line

Preliminary results for “**portable**” surface conductance

ECX Cavity with ferrite dampers

large beam tube, 24 cm dia, 2 dampers at 55 cm

- Power deposited

$P = 3.5 \text{ kW HOM} + 1.5 \text{ kW FRT}$
 $k_{\text{HOM}} = 3.5 \text{ V/pC}$, $k_{\text{FRT}} = 1.1 \text{ V/pC}$;
 $\sigma = 2 \text{ mm}$; $I = 0.3 \text{ A}$; $q_{\text{Bunch}} = 5 \text{ nC}$

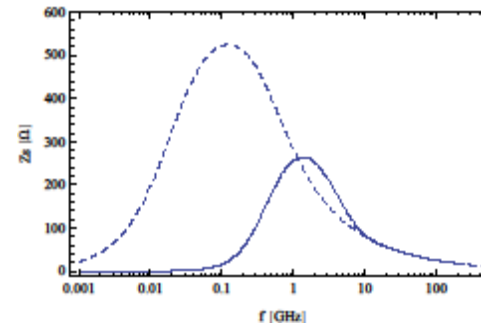
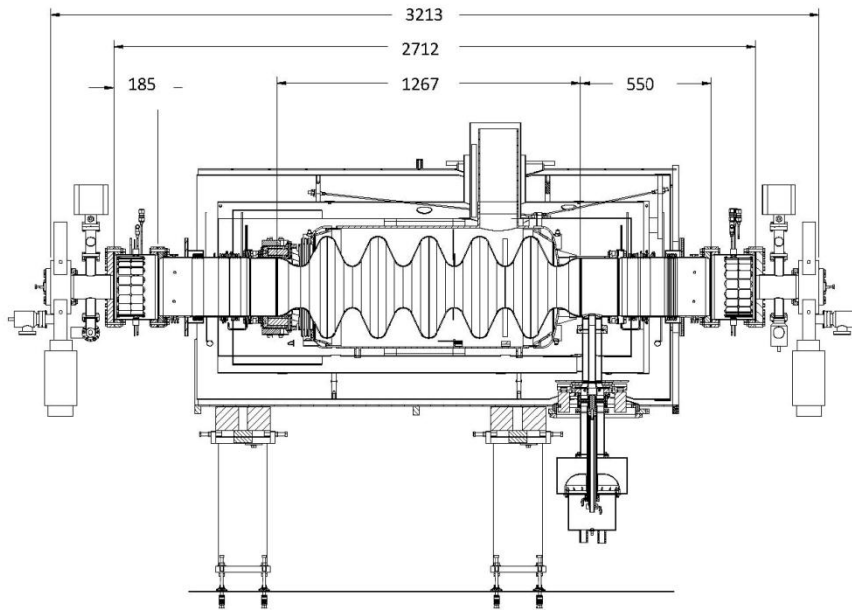

Ferrite HOM damper is reference

ECX Q and f (1/14/10)

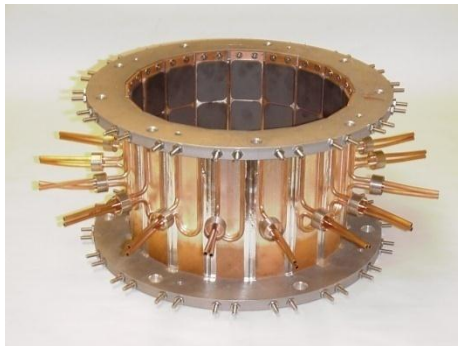

BTM BTM			
f [GHz]	40 K	4 K	2 K
		Q	Q
0.80514	900	874	
0.812515	170	170	
0.81959	130	141	
0.88458		49	
0.96001		43,500	
0.96018	9,500	44,200	47,800
0.96539	3350	4720	
0.97529	830	730	
0.99561	205	326	

ECX HOM f and Q-values

Table II: f and Q (Jan 14)

BTM BTM			
f [GHz]	40 K Q	4 K Q	2 K Q
1.6182		280	
1.6475		244	
1.6619		307	
1.6770		665	
1.6884		860	
1.6977		850	
1.7044		1,800	
1.7297		16,300	16,400
1.8347		1,640	
1.8384		1,250	
1.8690		540	
1.8909		2,430	
1.8942		4,940	
1.8949		10,860	12,250
1.8959		2,970	
1.8976		1,830	
1.9244		652	
1.9428		472	
2.0184		235	
2.0560		202	
2.1015		5,550	6060
2.1181		902	
2.1238		1,450	
2.2690		250	
2.2551		3,476	
2.2675		10,000	
2.3689			

f [GHz]

2.4557841
2.3442109
2.3298363
2.2138057
2.1483130
2.1476379

Q @ 4K

1,025,400
908,180
2,291,800
216,980
1,306,900
5,503,500

Table III High Q (14 Jan 2010)

BTM BTM			
f [GHz]	40 K Q	4 K Q	2 K Q
2.4626	1,270	735	
2.4831	870	838	
2.4821	880	910	
2.5057	18,700	43,300	36,200
2.5135	24,800	62,500	52,000
2.5160	25,000	75,400	108,900
3.0309	?	37,700	32,000
3.0339	49,300	155,000	275,000
3.0477		7,100	7,800
3.0766		?	
3.0839	7,600	10,500	9,900
3.1893		76,250	87000
3.1909		15,300	16100

ECX Q and f (1/14/10)

BTM BTM			
f [GHz]	40 K Q	4 K Q	2 K Q
0.80844	900	874	
0.82585	370	386	
0.84959	130	141	
0.88458		49	
0.96001		43,500	
0.96018	9,500	44,200	47,800
0.96639	3350	4720	
0.97829	830	730	
0.99561	205	326	
1.2233		17,600	82,800
1.2285		3738	4300
1.2341		5,790	5,800
1.2374		17,450	17,100
1.2663		4,900	5,700
1.2797		1,165	1,150
1.2965		1,283	
1.3024		3,740	4,450
1.3116		2,915	
1.3211		5,220	5,660
1.3252		474	
1.4694		172	

Capacitive HOM Dampers for He (work in progress)



Simulated and measured frequencies and their measured Q-values
 One ring with aligned mush room probes
 Q_x 50 mm dia Disk on 25 mm stub [Q_x @ fundamental $\sim 4 \times 10^3$]
 Q_x (wo) with Stub only

f_{MWS} [MHz]	f_{Data} [MHz]	Q_0	Q_L	Q_x	Q_x (wo)
808.8	806.3	11,370	9940	79,033	311,822
	814.3	7090	5310	21,151	125,194
826.2	825.1	17,050	4190	5555	42,889
	828.6	9450	2490	3381	24,249
849.1	847.1	1,440	3610	4936	44,270
	852.8	10,980	1680	1983	17,521
870.1	867.9	10,520	2770	3760	35,593
883.3	877.2	13,570	2603	3221	38,448
890.1	884.3	7990	3290	5593	50,046
959.4	958.2	35,390	29,460	175,816	4,283,410
	958.7	34,900	2,880	138,606	5,501,509
965.7	965.6	13,950	17,760	65,027	26,151
977.6	976.7	19,370	3440	4183	124,384
	978.0	23,400	13,000	29,250	165,414
994.4	994.5	1340	1100	1199	8335
	996.8	15,090	4840	7125	71,821

Frequencies and Q-values with staggered dampers
 70 mm probe spacing

f_{Data} [MHz]	Q_0	Q_L	Q_x
808.0	5810	3260	7428
808.6	4260	2520	6170
819.3	5660	4460	21,036
825.0	17,920	100	101
833.0	9740	4970	10,148
846.2	12,440	1540	1758
854.6	11,310	3280	4620
865.8	3420	10	10
877.0	12,180	1400	1582
883.2	6300	2040	3017
958.7	33,040	22,790	73,462
965.5	28,650	4830	2809
976.9	13,050	100	101
877.8	15,670	1850	2098
995.0	8660	3880	7029
996.4	8770	2240	3008



Frequency spectrum of a capacitive damper ring between Cu cavities.

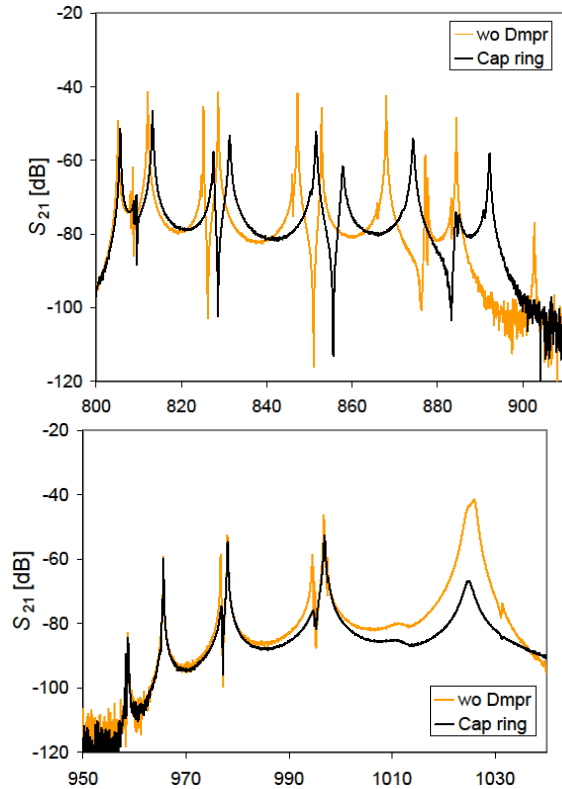

- Q-external of capacitive probes
 - at ~700 MHz

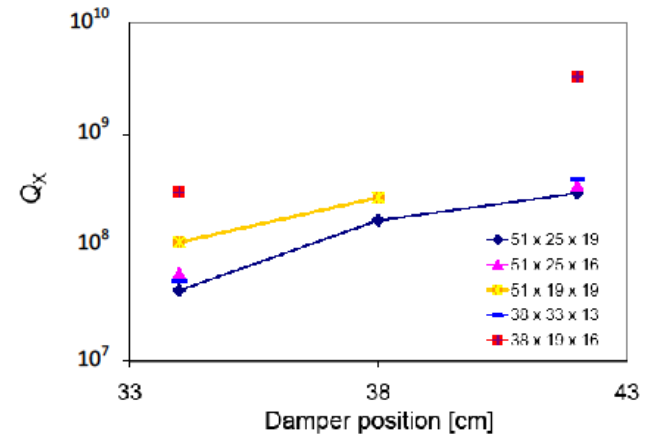

- BBU estimate for single pass
 - 5 Cell ERL

$$R_{SH} \approx 2c^2 / (e\omega T_{12} I)$$

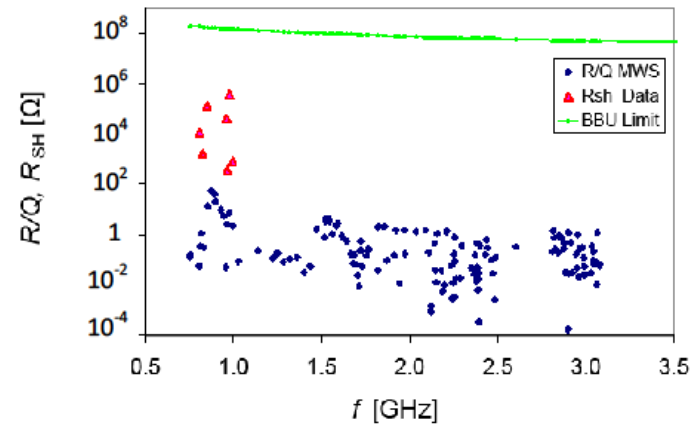

Damper Probe Impedance

Coax measurements

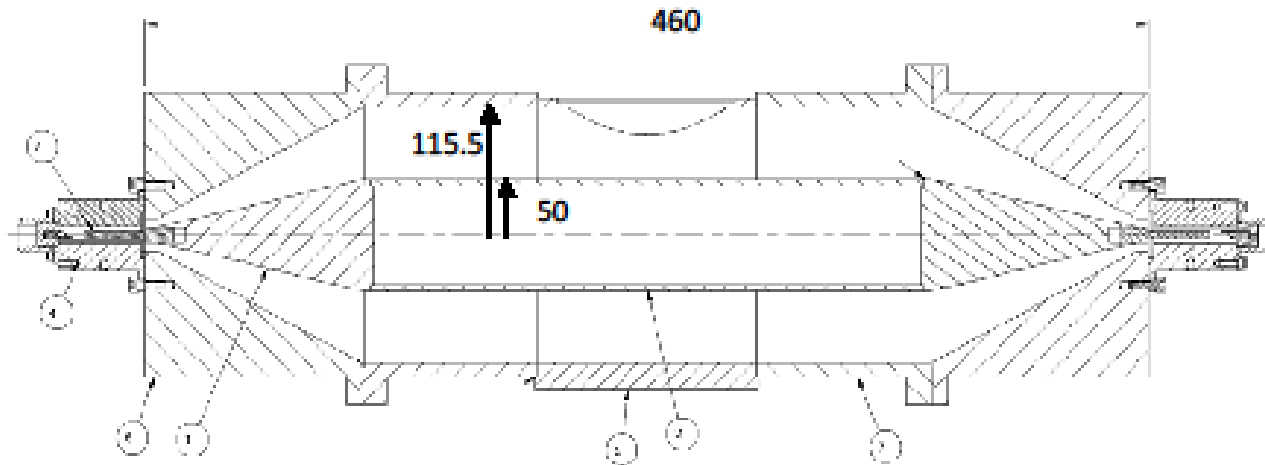

- Probe is Lumped Wall impedance for NWA measurement

-

- Input -> output S21 $Z_W = 2R_0 \frac{1 - \Delta S_{21}}{\Delta S_{21}}$

- Input -> top S21 $Z_W = 2R_0 \frac{\Delta S_{21}}{3 - \Delta S_{21}}$

- Damper loss, $b = 6 \text{ cm}$, $Z_0 = 377 \Omega$

$$P = Z_W \left(\frac{2\pi b}{Z_0} \right)^2 E_W^2$$

NWA measurement results coaxial connectors type N and EIA 1-5/8

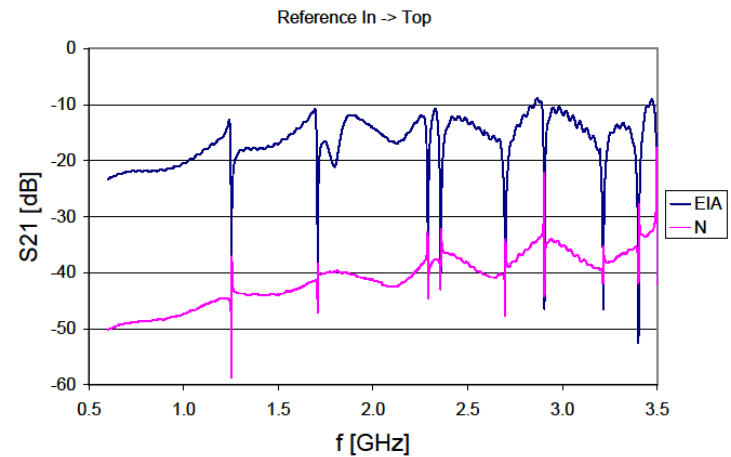
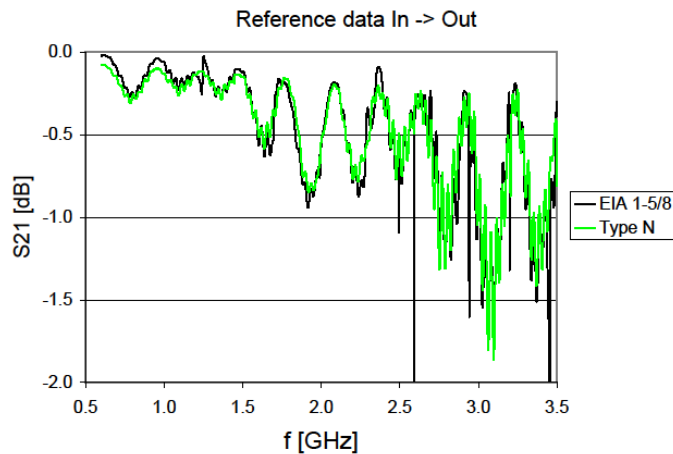



In -> Out S21 and ZW N & EIA connector



N S21 In - Out

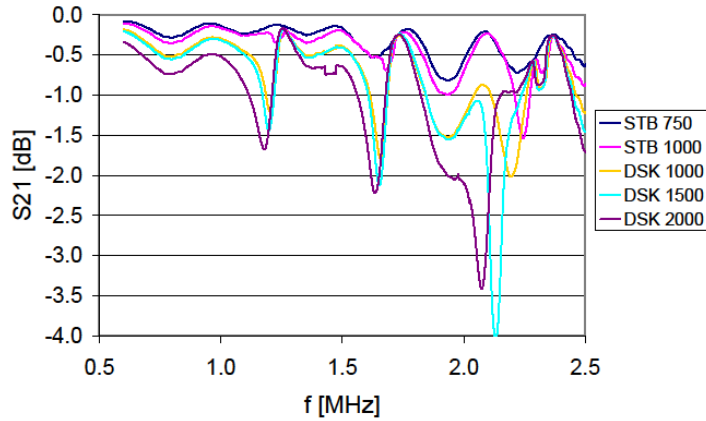

EIA S21 In - Out

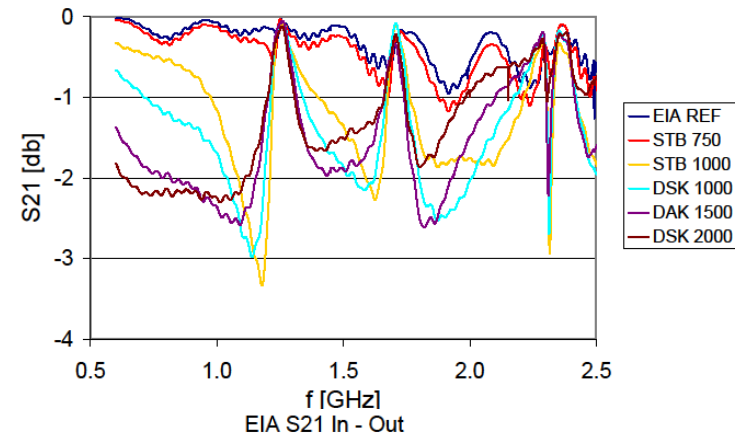

N -> ZW In - Out

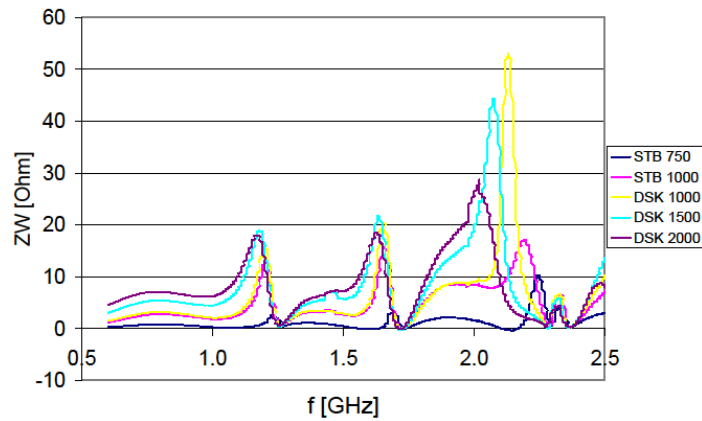

EIA S21 In - Out

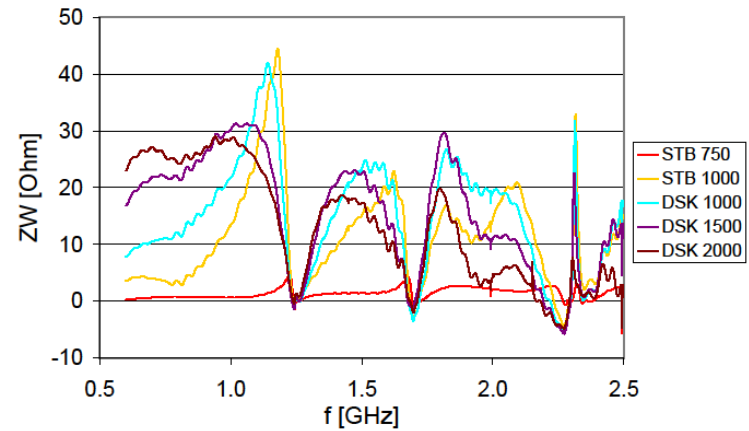

In -> Top S21 and ZW EIA connector

